

YAMAHA

PARTS CATALOGUE

YZ100K (5X3)

135X3-300E1



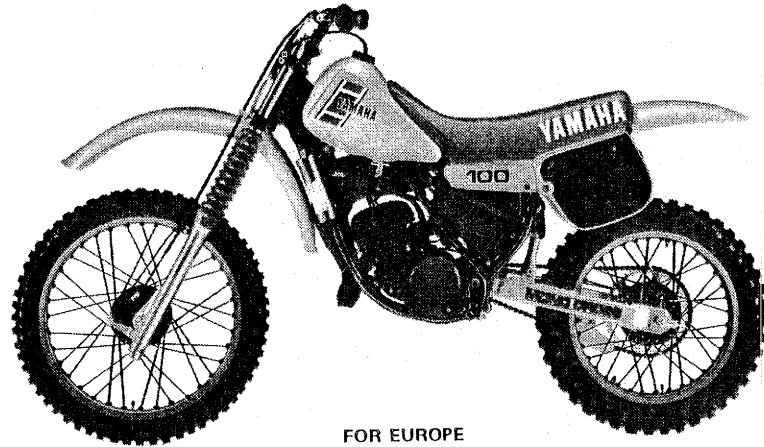

FOR EUROPE



FOR CANADA - OTHERS

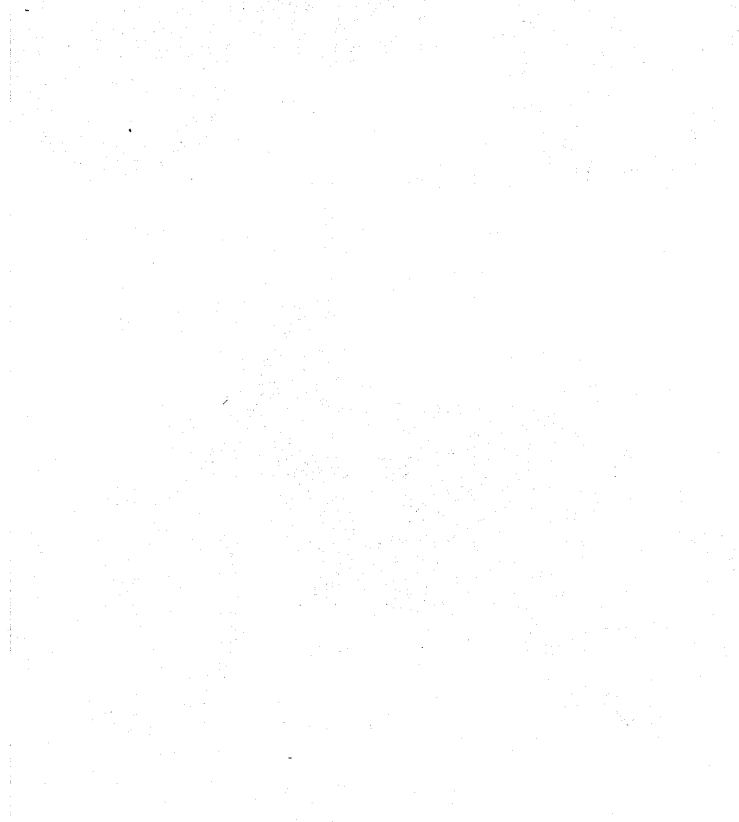

FOREWORD

This Parts Catalogue is related to the parts in use for the Yamaha YZ 100K (5X3).

When you are ordering replacement parts for the YZ 100K (5X3), refer to this Parts Catalogue and quote both part numbers and part names correctly.

1. Modifications or additions which have been made after issue of the Parts Catalogue will be announced in the Yamaha Parts News.

It is advisable that according to the Yamaha Parts News you make necessary corrections to the Parts Catalogue on hand to keep it up-to-date.

2. Abbreviations

The following abbreviations are used in this Parts Catalogue.

U.R. Use size (thickness) and/or number as required.

U.N. Use as many as you need.

A.P. Alternate Parts

L.M. Local Made

F# Frame No. (Applicable machine No.)

3. The parts marked with (*) in the parts number column of this Catalogue are not supplied with by Yamaha, those have to be found locally.

4. Parts, which are to be supplied in the form of assemblies, are listed with an indentation of one letter's space, and a dot (.) is put against the name of each part.

EXAMPLE CARBURETOR ASS'Y
 . JET, pilot
 . NOZZLE, main

5. Indication of No. of constituent parts for assembly

The numeral appearing to the right of each constituent part under the description indicates the quantity of such parts for each individual assembly unit.

EXAMPLE

Part No.	Description	Q'ty	Remarks
2F5-83310-60	FRONT FLASHER LIGHT ASS'Y	2	
115-83311-60	. BULB (6V-18W)	1	
1M1-83309-60	. REFLECTOR	1	

6. Initial Serial No. and Color Code

(A) Frame Serial No.	5X3-060101 and following
(B) Engine Serial No.	5X3-060101 and following

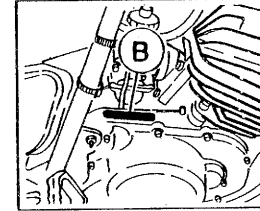
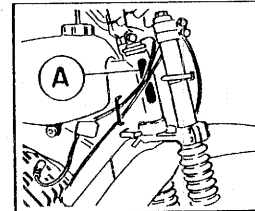

Color Code	Color Name	Abbreviate
36	Clean White	

7. Applicable colors of graphics are represented in the "Remarks" column by the letter(s) appropriately picked out of the full word(s) showing such colors.

EXAMPLE

Part No.	Description	Q'ty	Remarks
2N4-24110-00-X5	FUEL TANK COMP.	1	MAXIM RED
3J1-24240-10	. GRAPHIC, fuel tank set	1	for MXR

CONTENTS

ENGINE

Fig. 1	Cylinder Head · Cylinder	1
Fig. 2	Crankshaft · Piston	2
Fig. 3	C.D.I Magneto	3
Fig. 4	Intake	4
Fig. 5	Carburetor	6
Fig. 6	Exhaust	8
Fig. 7	Crankcase	9
Fig. 8	Crankcase Cover	10
Fig. 9	Kick Starter	11
Fig. 10	Clutch	12
Fig. 11	Transmission	13
Fig. 12	Shift Cam · Fork	15
Fig. 13	Shift Shaft · Pedal	16

CHASSIS

Fig. 14	Frame · Tool	17
Fig. 15	Front Fender · Rear Fender	18
Fig. 16	Side Cover	19
Fig. 17	Rear Arm	20
Fig. 18	Rear Suspension	22
Fig. 19	Steering	25
Fig. 20	Front Fork	26
Fig. 21	Fuel Tank	28
Fig. 22	Seat	29
Fig. 23	Front Wheel	30
Fig. 24	Rear Wheel	32
Fig. 25	Handlebar · Cable	34
Fig. 26	Stand · Footrest	35
Fig. 27	Electrical 1	36
Fig. 28	Handle Switch · Lever	37

REPAIR KIT

Fig. 29	Repair Kit	38
---------	------------	----

INDEX

Numerical Index
Parts Name Index

FIG. 1 CYLINDER HEAD, CYLINDER

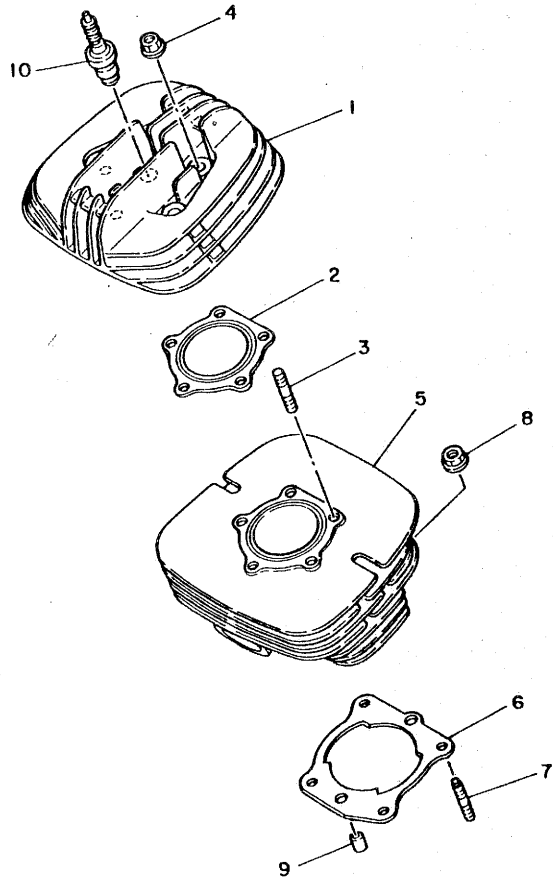

REF. NO.	PART NO.	DESCRIPTION	Q'TY	REMARKS
1	5X3-11111-00	HEAD, cylinder 1	1	
2	5X3-11181-00	GASKET, cylinder head 1	1	
3	90116-08394	BOLT, stud	5	
4	90179-08299	NUT	5	
5	5X3-11311-00	CYLINDER 1	1	
6	4V2-11351-00	GASKET, cylinder	1	
7	90116-10278	BOLT, stud	4	
8	90179-10292	NUT	4	
9	91830-21014	PIN, dowel	2	
10	*	PLUG, sPark (CHAMPION N-84)	1	LM



5X3100-2010

B2

FIG. 2 CRANKSHAFT.PISTON

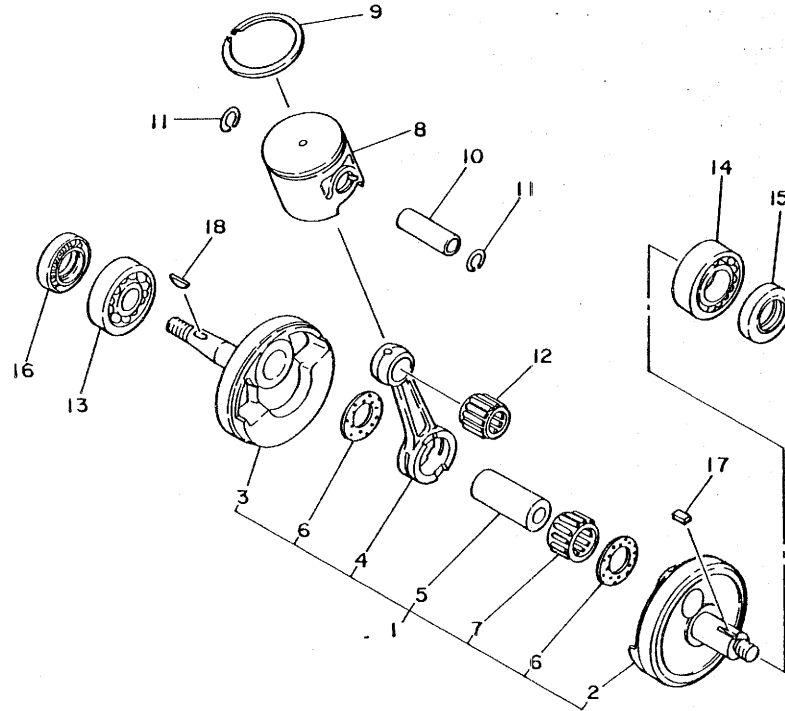

REF. NO.	PART NO.	DESCRIPTION	Q'TY	REMARKS
1	3R3-11400-00	CRANKSHAFT ASSY	1	
2	3R3-11412-00	.CRANK 1	1	
3	4V2-11422-00	.CRANK 2	1	
4	4V2-11651-00	.ROD, connecting	1	
5	3M5-11681-00	.PIN, crank 1	1	
6	90209-22071	.WASHER	2	
7	93310-422H0	.BEARING, cylindrical	1	
8	5X3-11631-01-97	PISTON (STD)	1	UR
	5X3-11631-01-98	PISTON (STD)	1	UR
	5X3-11635-01	PISTON (1ST O/S 0.25MM)	1	AP
	5X3-11636-01	PISTON (2ND O/S 0.50MM)	1	AP
	5X3-11637-01	PISTON (3RD O/S 0.75MM)	1	AP
	5X3-11638-01	PISTON (4TH O/S 1.00MM)	1	AP
9	5X3-11611-00	RING, Piston	1	
	5X3-11611-10	RING, Piston	1	AP
	5X3-11611-20	RING, Piston	1	AP
	5X3-11611-30	RING, Piston	1	AP
	5X3-11611-40	RING, Piston	1	AP
10	1J4-11633-00	PIN, Piston	1	
11	4V2-11634-00	CLIP, Piston Pin	2	
12	93310-216J2	BEARING, cylindrical	1	
13	93306-30406	BEARING (B6304C3)	1	
14	93306-20529	BEARING (B6205C4)	1	
15	93103-28126	OIL SEAL	1	
16	93102-25258	OIL SEAL	1	
17	90282-05038	KEY, straight	1	
18	90280-03017	KEY, woodruff	1	



5X3100-2021

B3

FIG. 3 C.D.I MAGNETO

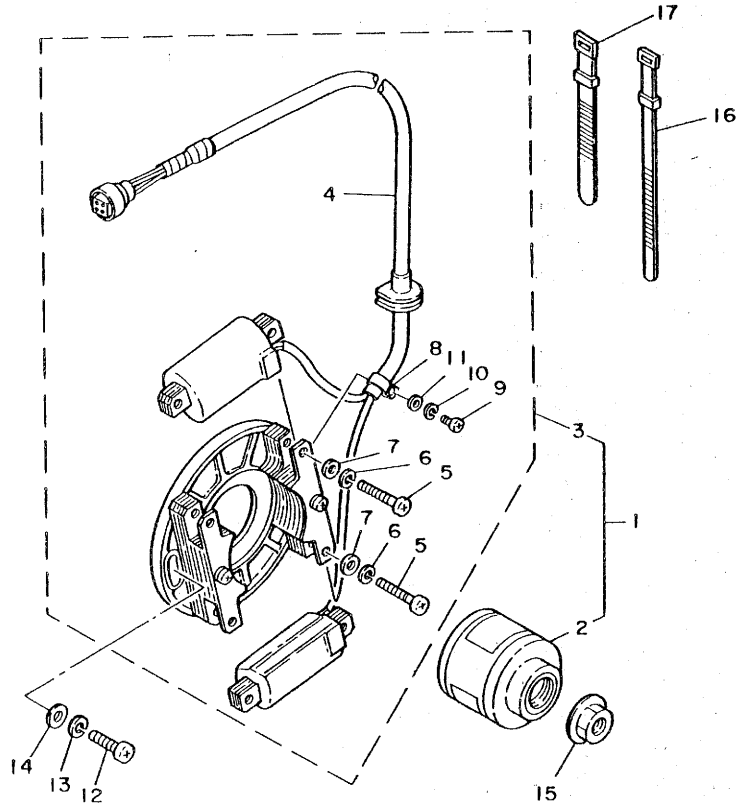

REF. NO.	PART NO.	DESCRIPTION	Q'TY	REMARKS
1	5X3-85500-10	C.D.I. MAGNETO ASSY	1	
2	5X3-85550-10	•ROTOR ASSY	1	
3	5X3-85510-11	•STATOR ASSY	1	
4	5X3-85520-10	••COIL, charge	1	
5	98501-05030	••SCREW, Pan head	6	
6	92901-05100	••WASHER, sPring	6	
7	92901-05600	••WASHER, Plate	6	
8	109-81328-11	••CLAMP	1	
9	98501-04008	••SCREW, Pan head	1	
10	92901-04100	••WASHER, sPring	1	
11	92901-04600	••WASHER, Plate	1	
12	92501-06020	SCREW, Pan head	2	
13	92901-06100	WASHER, sPring	2	
14	92901-06600	WASHER, Plate	2	
15	90179-10257	NUT	1	
16	437-83936-00	BAND, switch cord	3	
17	437-83936-10	BAND, switch cord	1	

FIG. 4 INTAKE

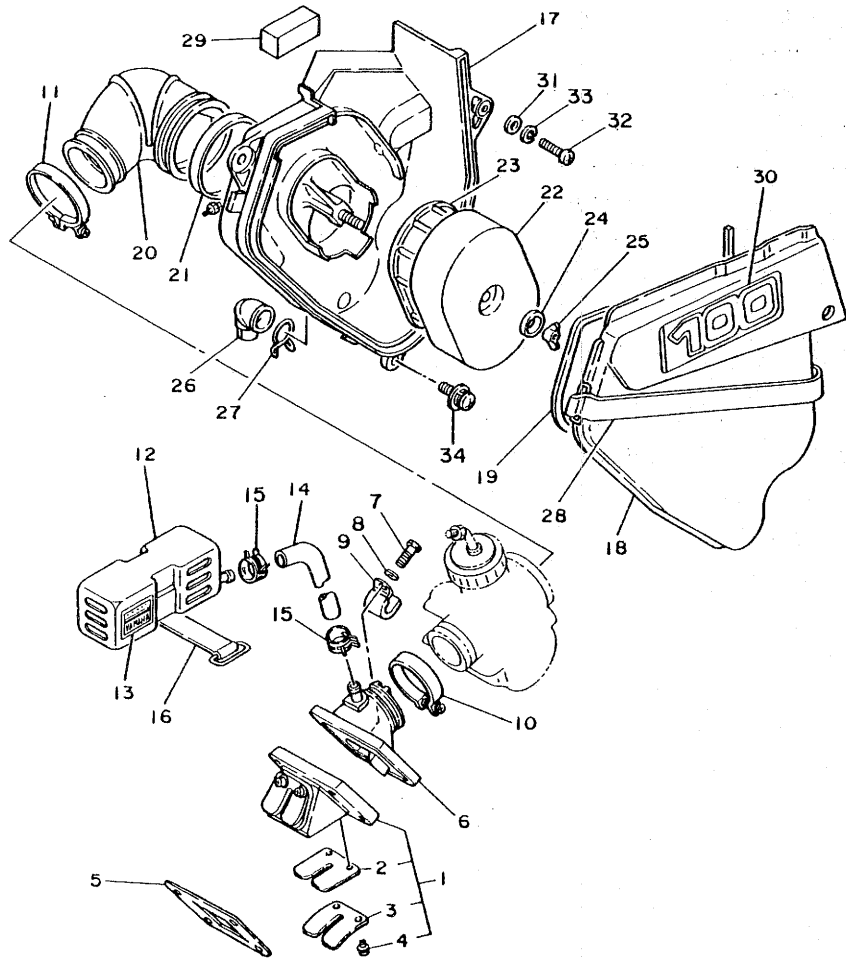

REF. NO.	PART NO.	DESCRIPTION	Q'TY	REMARKS
1	1L8-13610-00	REED VALVE ASSY	1	
2	1L8-13613-00	.REED, valve	2	
3	311-13616-01	.STOPPER, reed valve	2	
4	97602-03108	.SCREW, Pan head with washer	4	
5	10V-13621-00	GASKET, valve seat	1	
6	5X3-13565-00	JOINT, carburetor	1	
7	97301-06025	BOLT	4	
8	92901-06600	WASHER, Plate	4	
9	90462-05005	CLAMP	1	
10	90460-43053	CLAMP, hose	1	
11	90460-58807	CLAMP, hose	1	
12	5X2-13581-00	CHAMBER, air	1	
13	4V3-1441K-00	EMBLEM	1	
14	90445-15612	HOSE	1	
15	90467-16063	CLIP	2	
16	2T4-82131-00	BAND, battery	1	
17	5X3-14411-00	CASE, air cleaner 1	1	
18	5X3-14412-10	CAP, cleaner case 1	1	
19	5X4-14452-00	SEAL	1	
20	5X3-14453-00	JOINT, air cleaner 1	1	
21	90460-75020	CLAMP, hose	1	
22	5X4-W1442-00	ELEMENT, air cleaner	1	
23	5X4-14458-00	GUIDE	1	
24	2X4-14468-00	PLATE, element fitting	1	
25	90175-06012	NUT, wing	1	
26	1W1-14457-01	SEAL	1	
27	90467-20030	CLIP	1	
28	5X3-14455-00	BAND	1	



5X3100-2041

B5

FIG. 4 INTAKE

REF. NO.	PART NO.	DESCRIPTION	Q'TY	REMARKS
29	5X4-14462-00	SEAL	1	
30	5X3-21737-10	EMBLEM	1	
31	90201-06052	WASHER, Plate	1	
32	92501-06025	SCREW, Pan head	1	
33	92901-06100	WASHER, sPring	1	
34	90159-06060	SCREW, with washer	2	

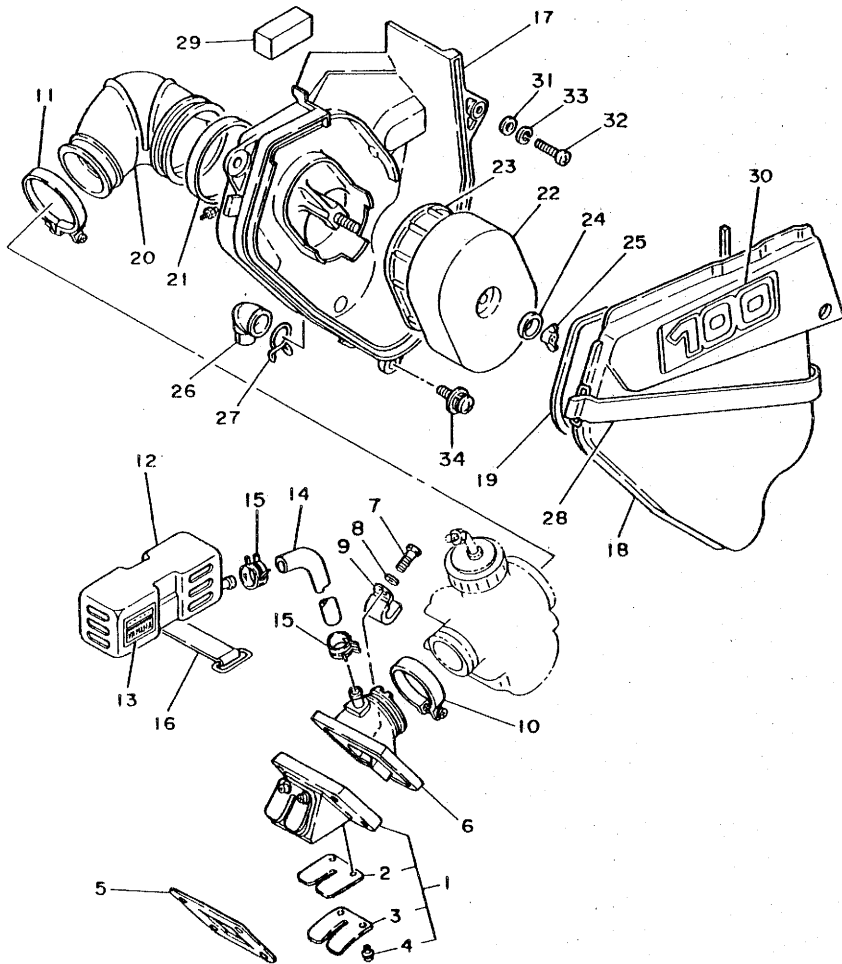

5X3100-2041

B6

FIG. 5 CARBURETOR

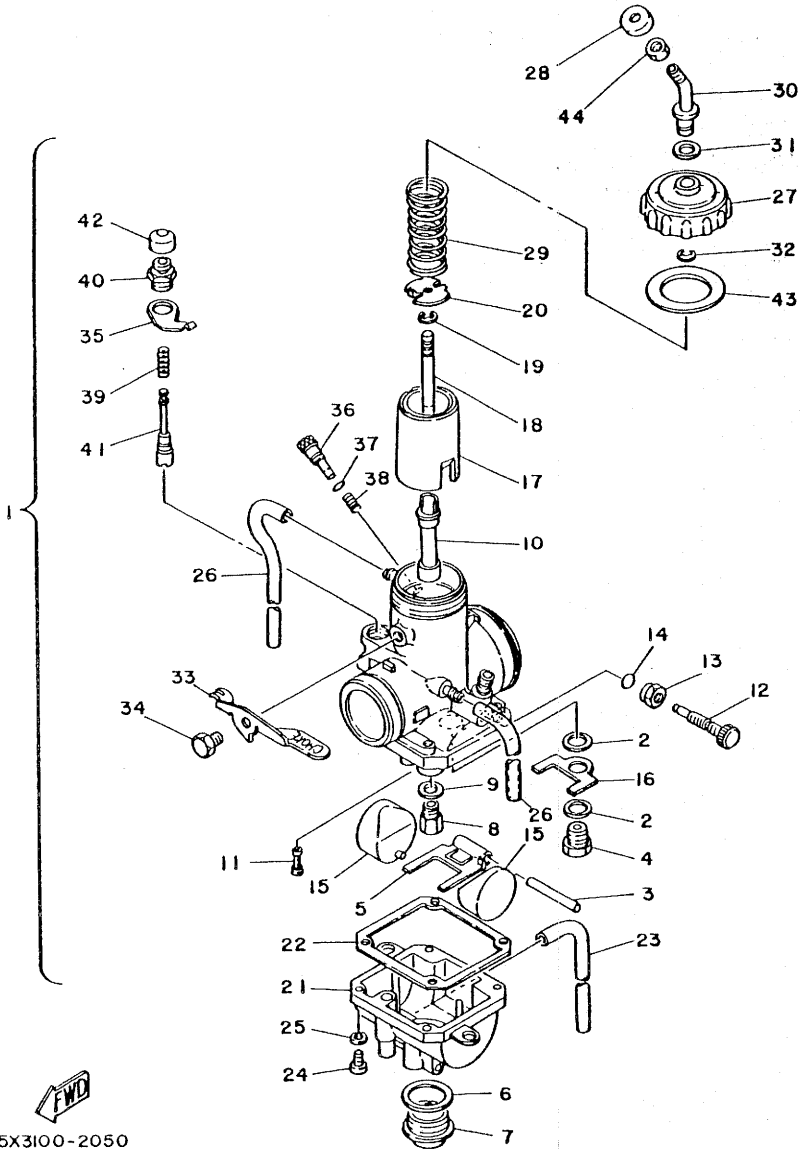

REF. NO.	PART NO.	DESCRIPTION	Q'TY	REMARKS
1	5X3-14101-00	CARBURETOR ASSY 1	1	
2	214-14195-00	.WASHER, needle valve	2	
3	537-14186-00	.PIN, float	1	
4	168-14190-28	.NEEDLE VALVE ASSY	1	
5	2K5-14187-00	.ARM, float	1	
6	278-14117-00	.WASHER, Plug screw	1	
7	537-14115-00	.PLUG, screw	1	
8	137-14143-36	.JET, main (#180)	1	UR
	137-14143-38	.JET, main (#190)	1	UR
	137-14143-40	.JET, main (#200)	1	UR
9	537-14153-00	.WASHER, main Jet	1	
10	278-14141-52	.NOZZLE, main	1	
11	193-14142-50	.JET, Pilot (#50.0)	1	
12	537-14122-00	.SCREW, throttle	1	
13	537-14161-00	.NUT, throttle screw	1	
14	214-14147-00	.O-RING	1	
15	280-14185-00	.FLOAT	2	
16	537-14146-00	.PLATE	1	
17	537-14112-25	.VALVE, throttle 1	1	
18	1J4-14116-10	.NEEDLE	1	
19	164-14137-00	.CLIP	1	
20	537-14136-00	.SEAT, sPring	1	
21	537-14181-16	.BODY, float chamber 1	1	
22	537-14184-00	.GASKET, float chamber	1	
23	183-14197-01	.PIPE	1	
24	98501-04016	.SCREW, Pan head	4	
25	92902-04100	.WASHER, sPring	4	
26	310-14196-00	.PIPE	2	

FWD
5X3100-2050

B7

FIG. 5 CARBURETOR

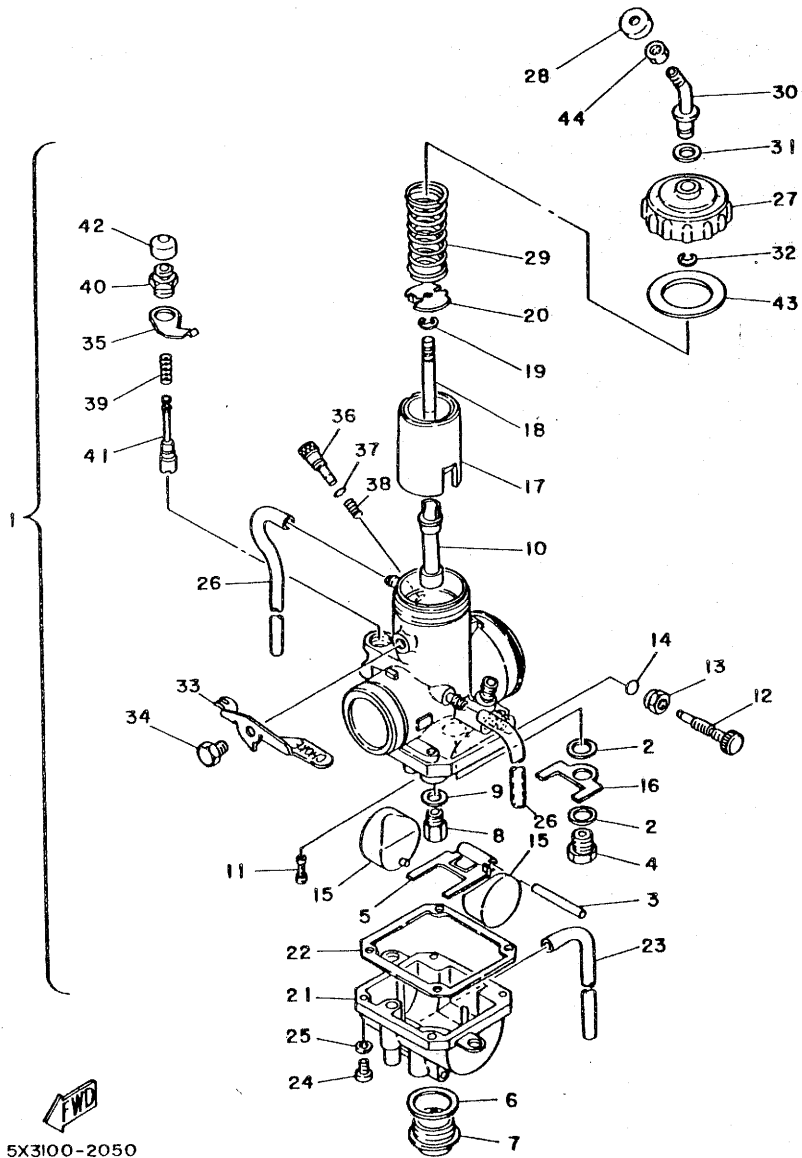

REF. NO.	PART NO.	DESCRIPTION	Q'TY	REMARKS
27	2K5-14158-00	•TOP, mixing chamber	1	
28	1M1-14169-00	•CAP	1	
29	537-14131-00	•SPRING, throttle valve	1	
30	2K5-14155-00	•HOLDER, guide	1	
31	363-14198-00	•GASKET	1	
32	363-14137-00	•CLIP	1	
33	537-14175-00	•LEVER, starter 1	1	
34	537-14162-00	•BOLT, starter lever	1	
35	537-14178-00	•PLATE, starter lever	1	
36	525-14123-00	•SCREW, air adjusting	1	
37	354-14147-00	•O-RING	1	
38	174-14134-00	•SPRING, air adjusting	1	
39	500-14135-00	•SPRING, Plunger	1	
40	802-14174-00	•CAP, Plunger	1	
41	174-14171-00	•PLUNGER, starter	1	
42	802-14173-00	•COVER, Plunger cap	1	
43	2K5-14198-00	•GASKET	1	
44	127-14161-00	•NUT, cable adjusting	1	

5X3100-2050

B8

FIG. 6 EXHAUST

REF. NO.	PART NO.	DESCRIPTION	Q'TY	REMARKS
1	5X3-14610-00	EXHAUST PIPE ASSY 1	1	
2	3R3-14613-00	GASKET, exhaust Pipe	1	
3	90507-20030	SPRING, tension	2	
4	565-14771-00	STAY, muffler 1	1	
5	97301-06012	BOLT	2	
6	92901-06100	WASHER, sPrinG	2	
7	5X4-14753-00	SILENCER, exhaust	1	
8	90109-08512	BOLT	1	
9	90201-08114	WASHER, Plate	1	
10	90480-22269	GROMMET	1	
11	90387-081A3	COLLAR	1	

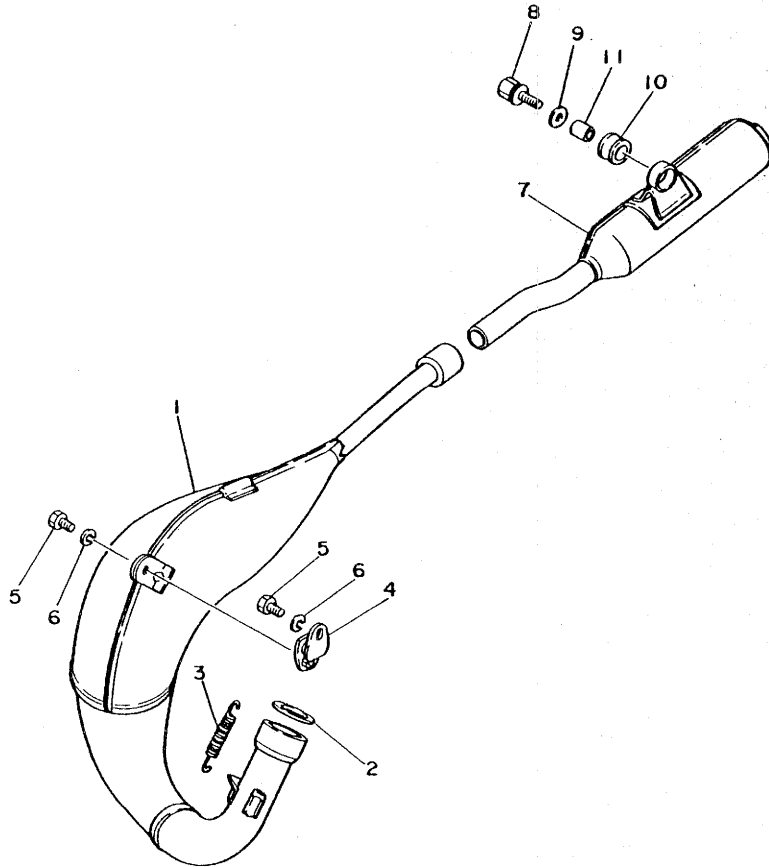

5X3100-2060

B9

FIG. 7 CRANKCASE

REF. NO.	PART NO.	DESCRIPTION	Q'TY	REMARKS
1	5X3-15111-00	CRANKCASE 1	1	
2	4V2-15121-00	CRANKCASE 2	1	
3	90387-16781	COLLAR	2	
4	91830-21014	PIN, dowel	2	
5	91316-06035	BOLT	9	
6	91316-06050	BOLT	1	
7	2N4-15371-00	BREATHER	1	
8	90445-07340	HOSE	1	
9	90338-07011	PLUG	1	
10	90340-12059	PLUG, straight screw	1	
11	90430-12038	GASKET	1	
12	3R3-15128-01	HOLDER	2	
13	92501-08010	SCREW, Pan head	2	

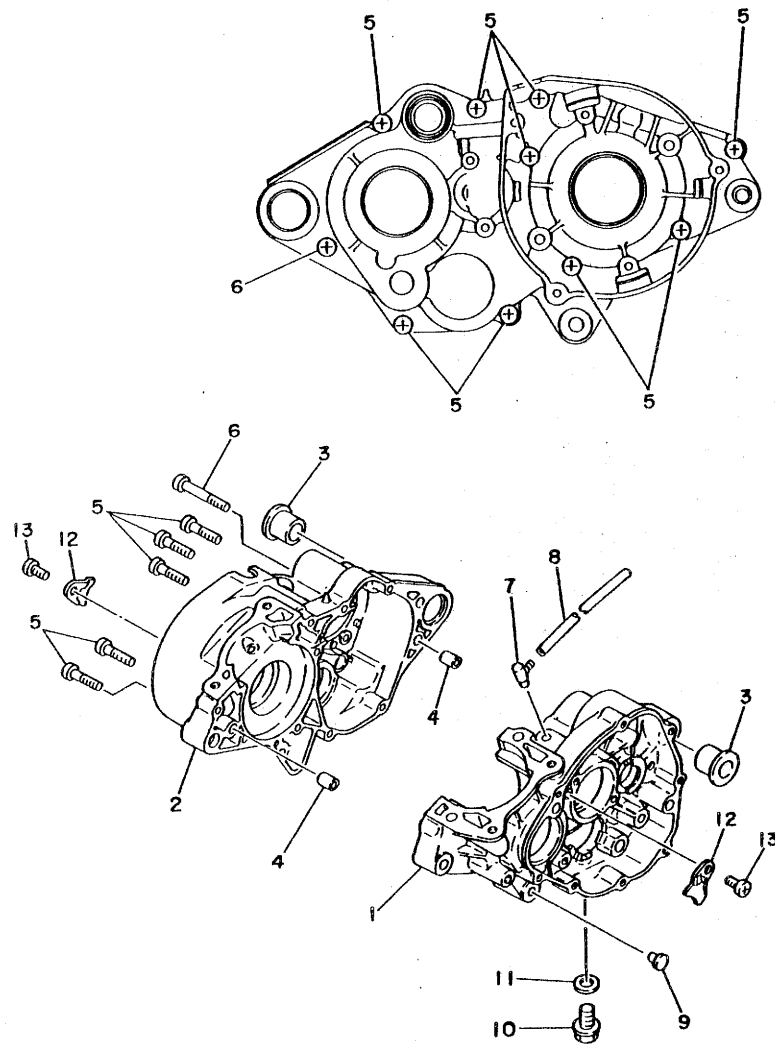

5X3100-2070

B10

FIG. 8 CRANKCASE COVER

REF. NO.	PART NO.	DESCRIPTION	Q'TY	REMARKS
1	3R3-15411-00	COVER, crankcase 1	1	
2	3R3-15451-01	GASKET, crankcase cover	1	
3	92506-06025	SCREW, Pan head	8	
4	91830-21014	PIN, dowel	2	
5	1G8-15362-00	PLUG, oil level	1	
6	93210-14104	O-RING	1	
7	92506-06008	SCREW, Pan head	1	
8	90430-06016	GASKET	1	
9	3R3-15421-00	COVER, crankcase 2	1	
10	4V2-15455-00	GASKET 1	1	
11	92506-06025	SCREW, Pan head	3	
12	3R3-15431-00	COVER, crankcase 3	1	
13	92501-06015	SCREW, Pan head	1	
14	90201-06067	WASHER, Plate	1	
15	92501-06020	SCREW, Pan head	1	
16	92901-06200	WASHER, Plain	1	

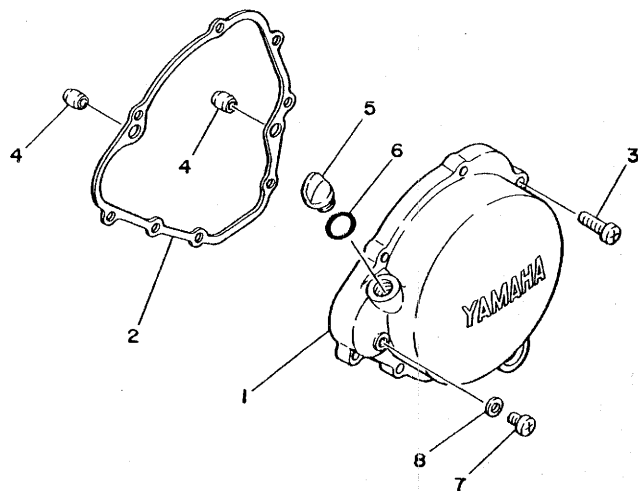
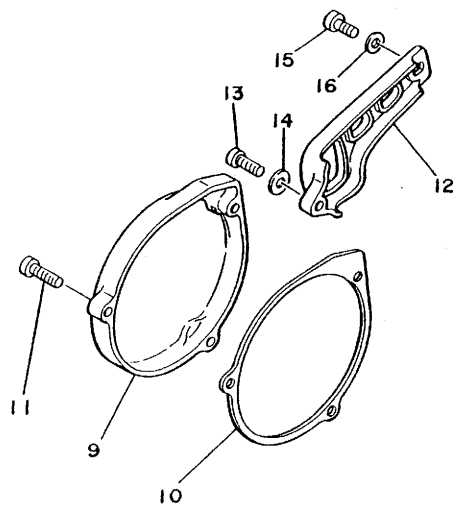

5X3100-2080

B11

FIG. 9 KICK STARTER

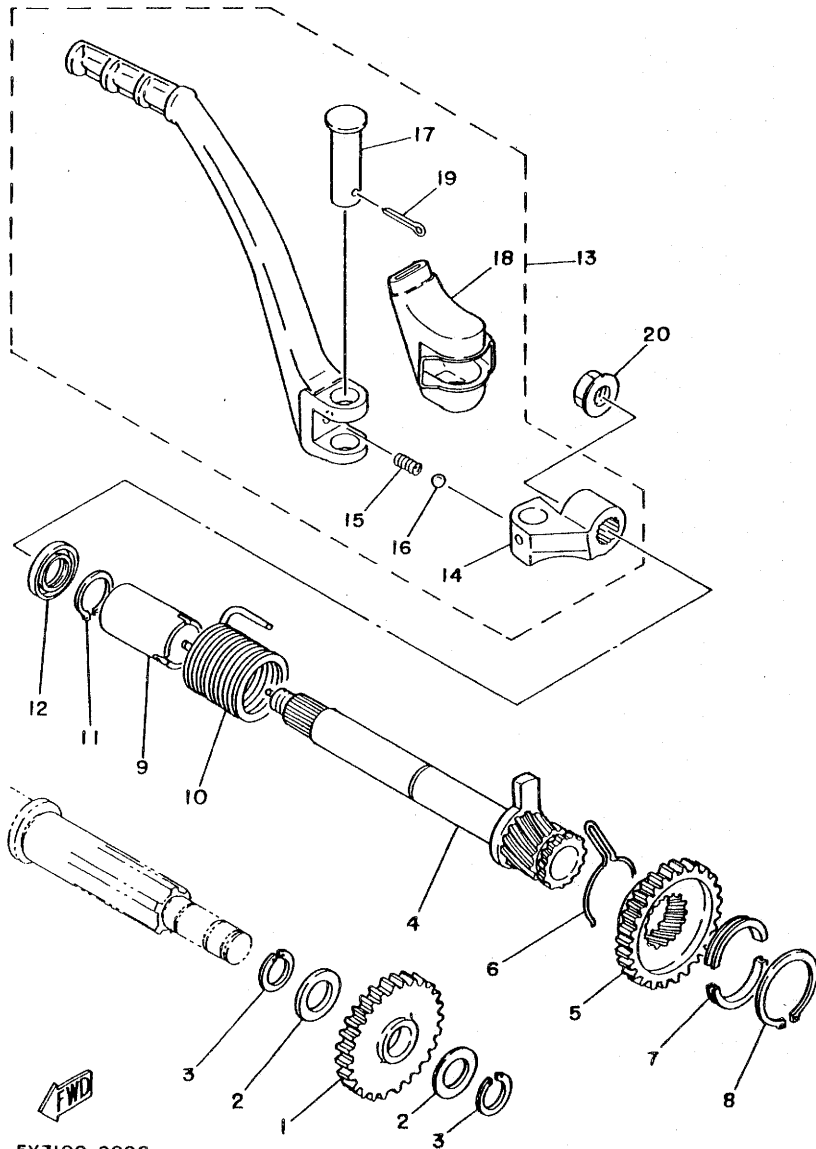

REF. NO.	PART NO.	DESCRIPTION	Q'TY	REMARKS
1	3R3-15651-01	GEAR, sPcket idle (25T)	1	
2	137-17417-00-05	SHIM (0.5T)	2	
3	93440-15012	CIRCLIP	2	
4	3R3-15660-00	KICK AXLE ASSY	1	
5	3R3-15641-00	GEAR, kick (25T)	1	
6	90468-26048	CLIP	1	
7	248-15654-00	HOLDER, kick gear	2	
8	93410-30012	CIRCLIP	1	
9	3R3-15666-00	SPACER	1	
10	90508-26427	SPRING, torsion	1	
11	93410-17037	CIRCLIP	1	
12	93101-17062	OIL SEAL	1	
13	5X3-15620-00	KICK CRANK ASSY	1	
14	5X3-15621-00	•BOSS, kick crank	1	
15	90501-12081	•SPRING, compression	1	
16	93507-32009	•BALL	1	
17	91702-12040	•PIN, clevis	1	
18	3R3-15618-01	•COVER, kick lever	1	
19	91401-40020	•PIN, cotter	1	
20	90179-10272	NUT	1	

5X3100-2090

B12

FIG. 10 CLUTCH

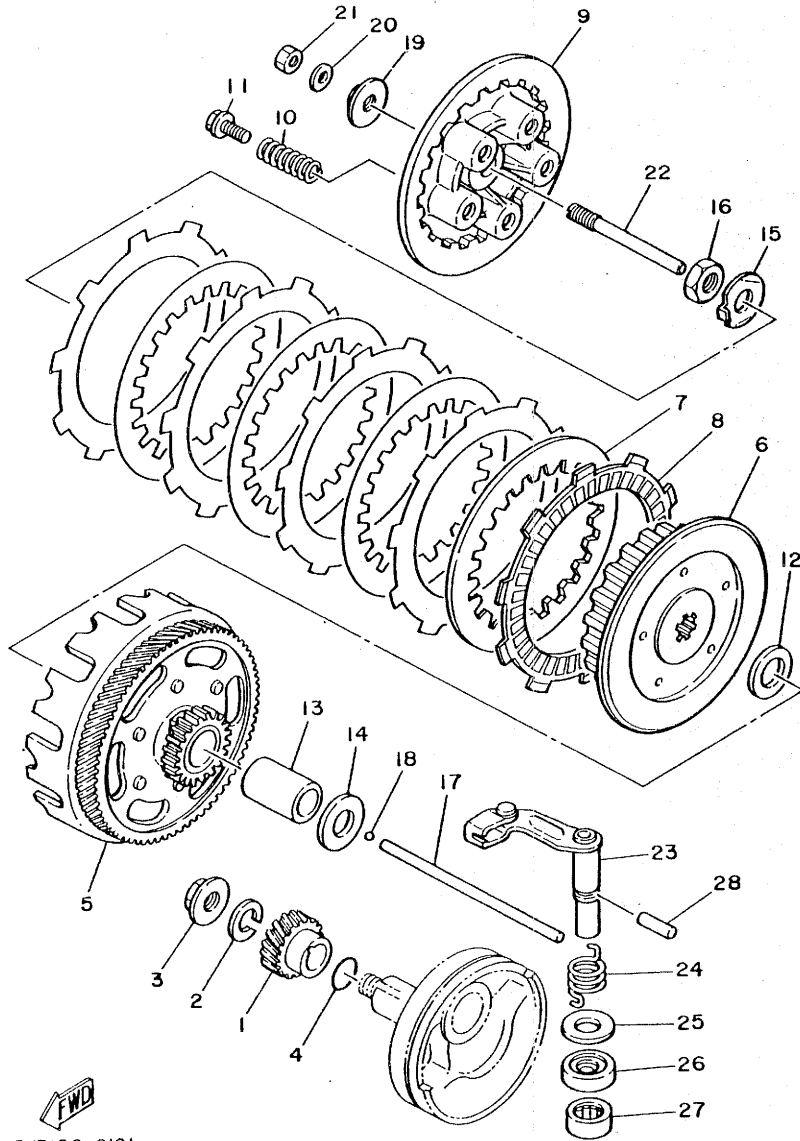

5X3100-2101

B13

REF. NO.	PART NO.	DESCRIPTION	Q'TY	REMARKS
1	3R3-16111-00	GEAR, Primary drive (18T)	1	
2	90204-12007	WASHER, sPring	1	
3	90179-12302	NUT	1	
4	93210-20027	O-RING	1	
5	3R3-16150-00	DRIVEN GEAR ASSY (62T)	1	
6	1G8-16371-00	BOSS, clutch	1	
7	3R3-16325-00	PLATE, clutch 2	4	
8	537-16321-00	PLATE, friction	5	
9	1W1-16351-00	PLATE, Pressure 1	1	
10	90501-20361	SPRING, comPression	5	
11	90159-05011	SCREW, with washer	5	
12	90201-17550	WASHER, Plate	1	
13	90560-17190	SPACER	1	
14	90201-17550	WASHER, Plate	1	
15	90215-14204	WASHER, lock	1	
16	90170-14171	NUT	1	
17	2X3-16357-00	ROD, Push 2	1	
18	93503-16010	BALL	1	
19	1W1-16358-00	PLATE, Push	1	
20	92901-06200	WASHER, Plain	1	
21	95301-06600	NUT	1	
22	1W1-16356-01	ROD, Push 1	1	
23	3R3-16380-02	PUSH LEVER ASSY	1	
24	90508-14426	SPRING, torsion	1	
25	90201-14217	WASHER, Plate	1	
26	93104-14004	OIL SEAL	1	
27	93315-21429	BEARING, cylindrical	1	
28	93604-16092	PIN, dowel	1	

FIG. 11 TRANSMISSION

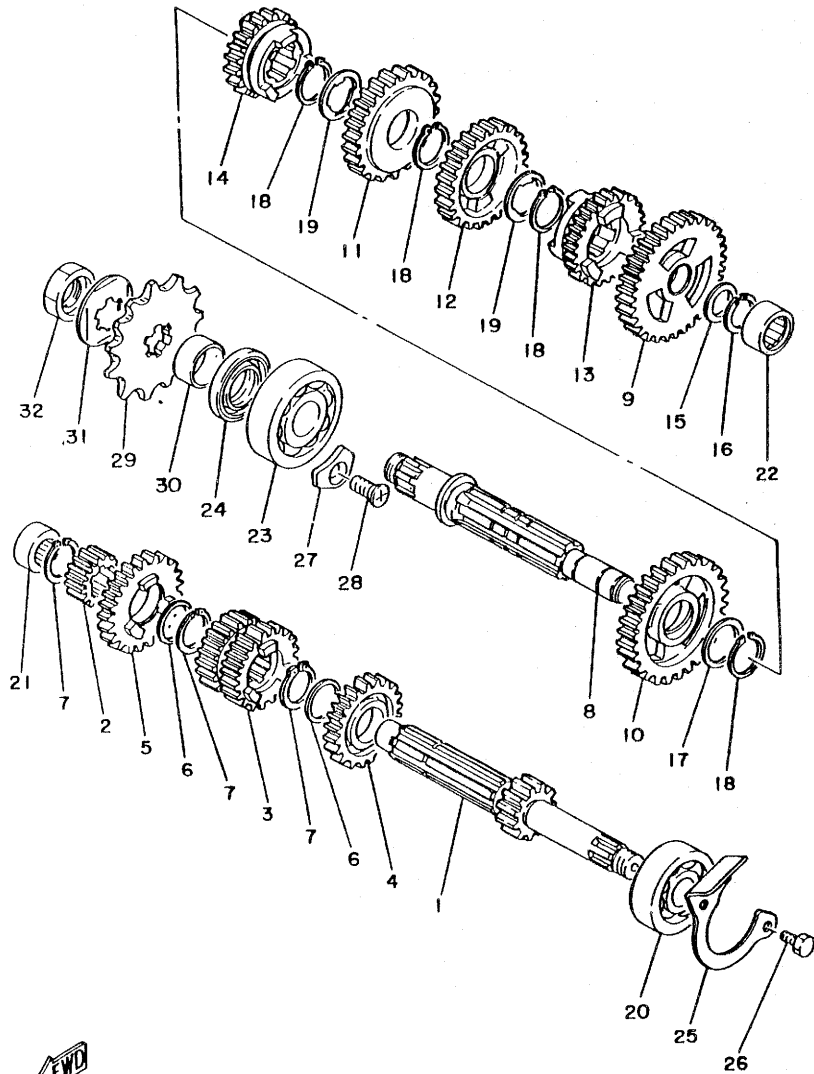

REF. NO.	PART NO.	DESCRIPTION	Q'TY	REMARKS
1	3R3-17411-00	AXLE, main (13T)	1	
2	5X4-17121-01	GEAR, 2nd Pinion (14T)	1	
3	3R3-17131-01	GEAR, 3rd/4th Pinion (16T,20T)	1	
4	3R3-17151-02	GEAR, 5th Pinion (19T)	1	
5	3R3-17161-02	GEAR, 6th Pinion	1	
6	90201-20266	WASHER, Plate	2	
7	93410-20038	CIRCLIP	3	
8	3R3-17421-00	AXLE, drive	1	
9	5X4-17211-01	GEAR, 1st wheel (32T)	1	
10	3R3-17221-01	GEAR, 2nd wheel (26T)	1	
11	3R3-17231-01	GEAR, 3rd wheel (24T)	1	
12	3R3-17241-01	GEAR, 4th wheel (25T)	1	
13	3R3-17251-02	GEAR, 5th wheel (21T)	1	
14	3R3-17261-02	GEAR, 6th wheel	1	
15	90201-15701	WASHER, Plate (1.0T)	1	
16	93440-15012	CIRCLIP	1	
17	90201-22555	WASHER, Plate	1	
18	93410-22039	CIRCLIP	4	
19	90209-18135	WASHER	2	
20	93306-30303	BEARING (B6303Z)	1	
21	93311-41530	BEARING, cylindrical	1	
22	93311-31515	BEARING, cylindrical	1	
23	93306-30411	BEARING (B6304)	1	
24	93102-26042	OIL SEAL	1	
25	3R3-17471-00	PLATE, cover	1	
26	97321-06012	BOLT	2	
27	2K7-15383-00	PLATE, bearing cover	1	
28	92701-06012	SCREW, flat head	1	



5X3100-2110

B14

FIG. 11 TRANSMISSION

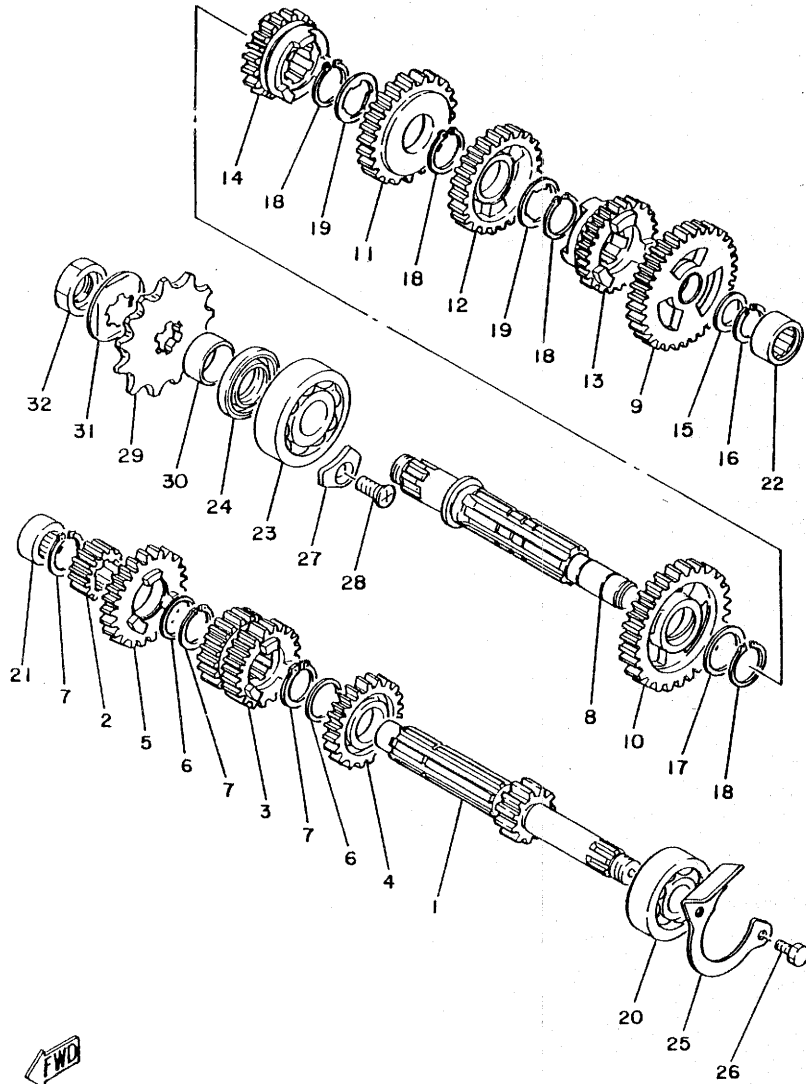

REF. NO.	PART NO.	DESCRIPTION	Q'TY	REMARKS
29	1W1-17461-20	SPROCKET, drive (12T)	1	STD
	1G8-17461-10	SPROCKET, drive (11T)	1	AP
	1G8-17461-30	SPROCKET, drive (13T)	1	AP
30	90387-202A0	COLLAR	1	
31	90215-16127	WASHER, lock	1	
32	90179-16226	NUT	1	

5X3100-21 10

B15

FIG. 12 SHIFT CAM.FORK

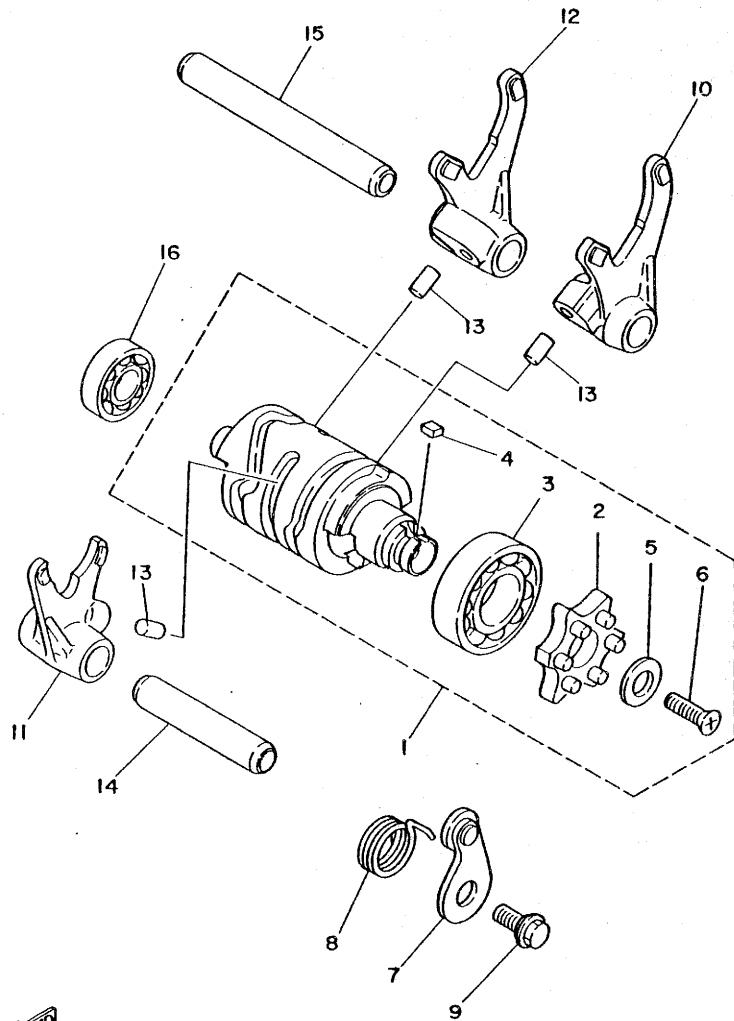

REF. NO.	PART NO.	DESCRIPTION	Q'TY	REMARKS
1	5X4-18540-00	SHIFT CAM ASSY	1	
2	3R4-18185-00	.SEGMENT	1	
3	93306-00422	.BEARING	1	
4	90282-04036	.KEY, straight	1	
5	3R4-18561-00	.PLATE, side 1	1	
6	98701-05016	.SCREW, flat head	1	
7	3R3-18140-00	STOPPER LEVER ASSY	1	
8	90508-26515	SPRING, torsion	1	
9	1W1-18177-00	BOLT, stopper	1	
10	3R3-18511-00	FORK, shift 1	1	
11	3R3-18512-00	FORK, shift 2	1	
12	3R3-18513-00	FORK, shift 3	1	
13	90250-06013	PIN, straight	3	
14	3R4-18531-00	BAR, shift fork guide 1	1	
15	3R4-18535-00	BAR, shift fork guide 2	1	
16	93306-20107	BEARING (B6201)	1	



5X4100-2150

C2

FIG. 13 SHIFT SHAFT-PEDAL

REF. NO.	PART NO.	DESCRIPTION	Q'TY	REMARKS
1	5X4-18101-00	SHIFT SHAFT ASSY	1	
2	5X4-18110-01	SHIFT PEDAL ASSY	1	
3	1W6-18113-00	COVER, shift Pedal	1	
4	97321-06020	BOLT	1	
5	93101-12060	OIL SEAL	1	
6	93608-25150	PIN, dowel	1	
7	90560-11189	SPACER	1	
8	90508-29361	SPRING, torsion	1	
9	93430-10016	CIRCLIP	1	

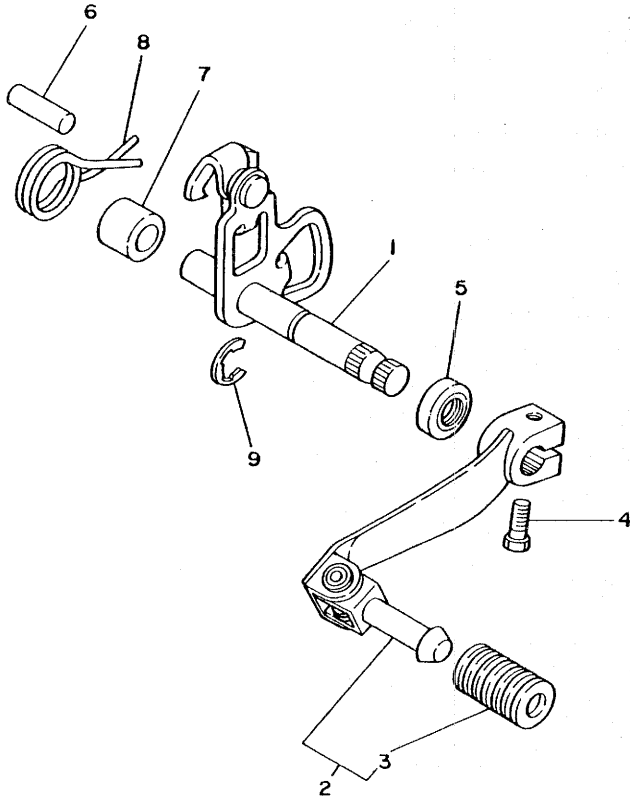

5X3100-3130

C3

FIG. 14 FRAME • TOOL

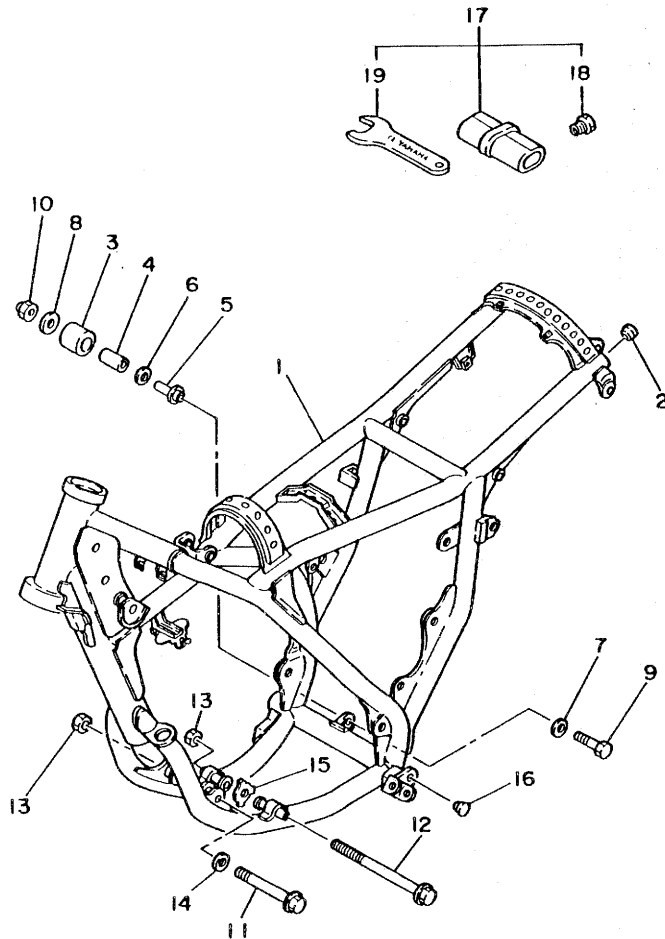

REF. NO.	PART NO.	DESCRIPTION	Q'TY	REMARKS
1	5X3-21110-00-33	FRAME COMP	1	yamaha black
2	90339-13005	PLUG	2	
3	4V4-22178-00	TENSIONER	1	
4	4V4-22184-00	BUSH	1	
5	3R3-2148A-00	SHAFT	1	
6	90201-13202	WASHER, Plate	1	
7	90201-08113	WASHER, Plate	1	
8	90201-08638	WASHER, Plate	1	
9	97302-08050	BOLT	1	
10	95602-08100	NUT, u	1	
11	95811-08100	BOLT, flange	1	
12	95811-08165	BOLT, flange	1	
13	90185-08089	NUT, self-locking	2	
14	92901-08200	WASHER, Plain	1	
15	90214-09019	WASHER, claw	1	
16	90338-12131	PLUG	1	
17	5X3-28100-00	TOOL KIT	1	
18	2K7-85555-00	•PULLER, rotor	1	
19	1W1-28135-10	•SPANNER, sPecial	1	



5X3100-2140

C4

FIG. 15 FRONT FENDER•REAR FENDER

REF. NO.	PART NO.	DESCRIPTION	Q'TY	REMARKS
1	5X6-21511-10	FENDER, front	1	white
2	90201-06557	WASHER, Plate	4	
3	97302-06020	BOLT	4	
4	92902-06100	WASHER, sPring	4	
5	90209-06187	WASHER	4	
6	3R3-21611-11	FENDER, rear	1	white
7	90201-06571	WASHER, Plate	4	
8	97301-06016	BOLT	4	
9	92902-06100	WASHER, sPring	4	
10	95601-06100	NUT, u	2	
11	5X3-21620-00	MUD GUARD COMP.	1	
12	565-21746-00	.SEAL, mud Guard	1	
13	5X3-21642-00	.GUARD, flap	1	
14	437-83936-00	BAND, switch cord	4	
15	90201-06571	WASHER, Plate	1	
16	92501-06015	SCREW, Pan head	1	
17	92901-06100	WASHER, sPring	1	

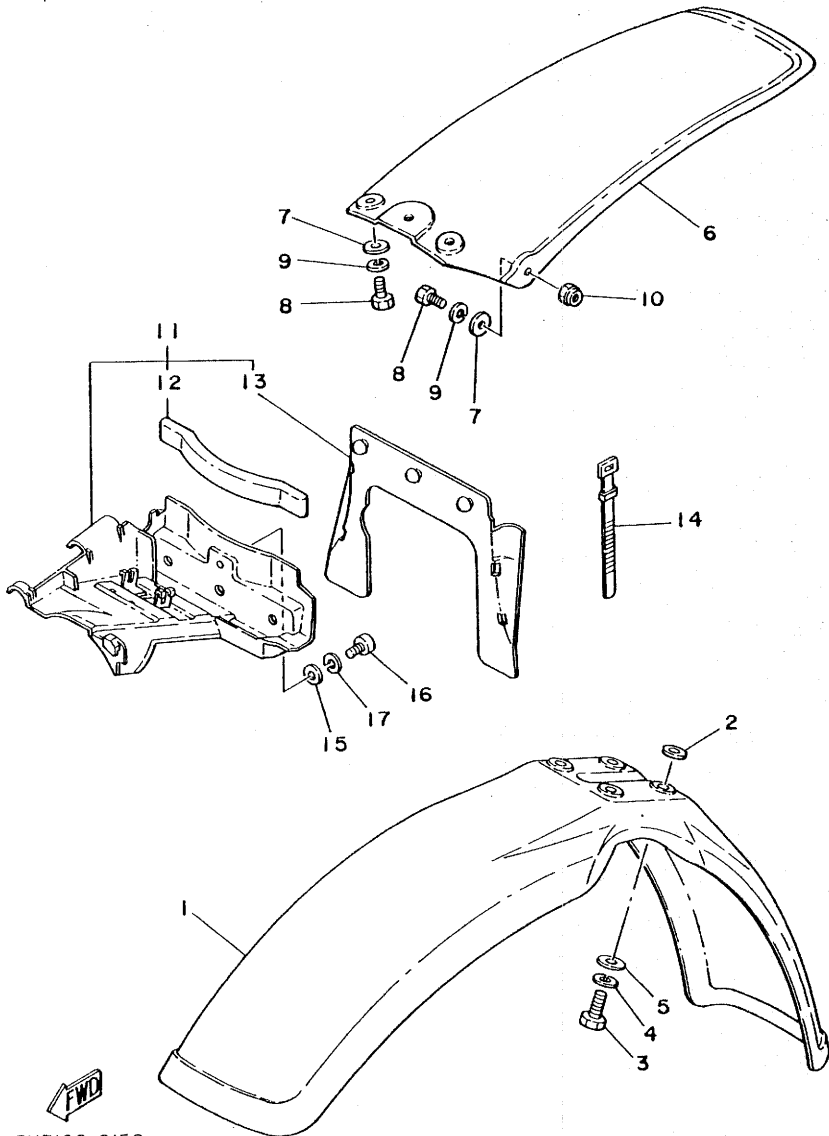

5X3100-2150

C5

FIG. 16 SIDE COVER

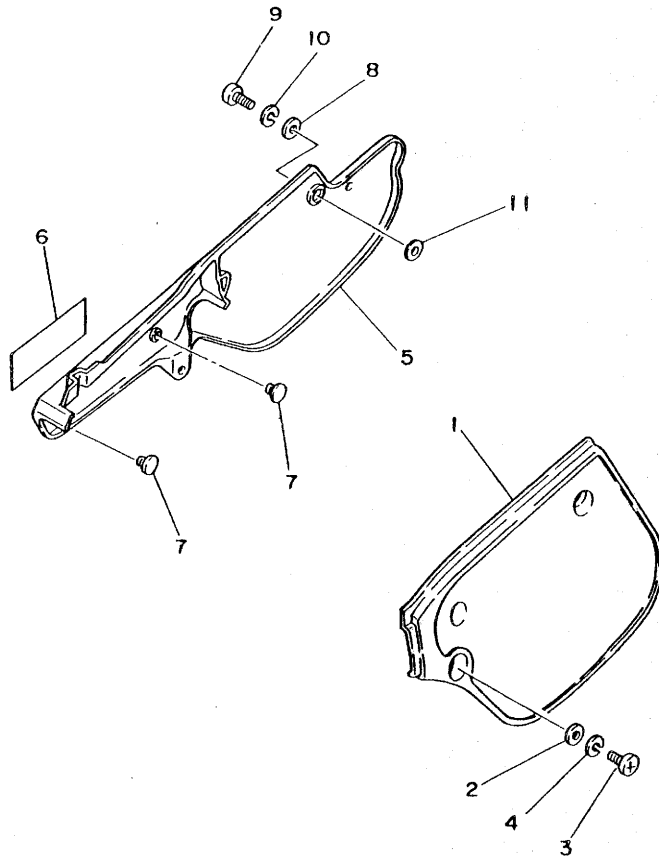

REF. NO.	PART NO.	DESCRIPTION	Q'TY	REMARKS
1	5X4-21711-10-98	COVER, side 1	1	low gloss black /white
2	90201-06571	WASHER, Plate	2	
3	92501-06015	SCREW, Pan head	2	
4	92901-06100	WASHER, sPring	2	
5	5X4-21721-10-98	COVER, side 2	1	low gloss black /white
6	5X3-21737-10	EMBLEM	1	
7	431-24181-00	DAMPER, locating 1	4	
8	90201-06571	WASHER, Plate	2	
9	92501-06015	SCREW, Pan head	2	
10	92901-06100	WASHER, sPring	2	
11	92901-08200	WASHER, Plain	1	



5X3300-3160

C6

FIG. 17 REAR ARM

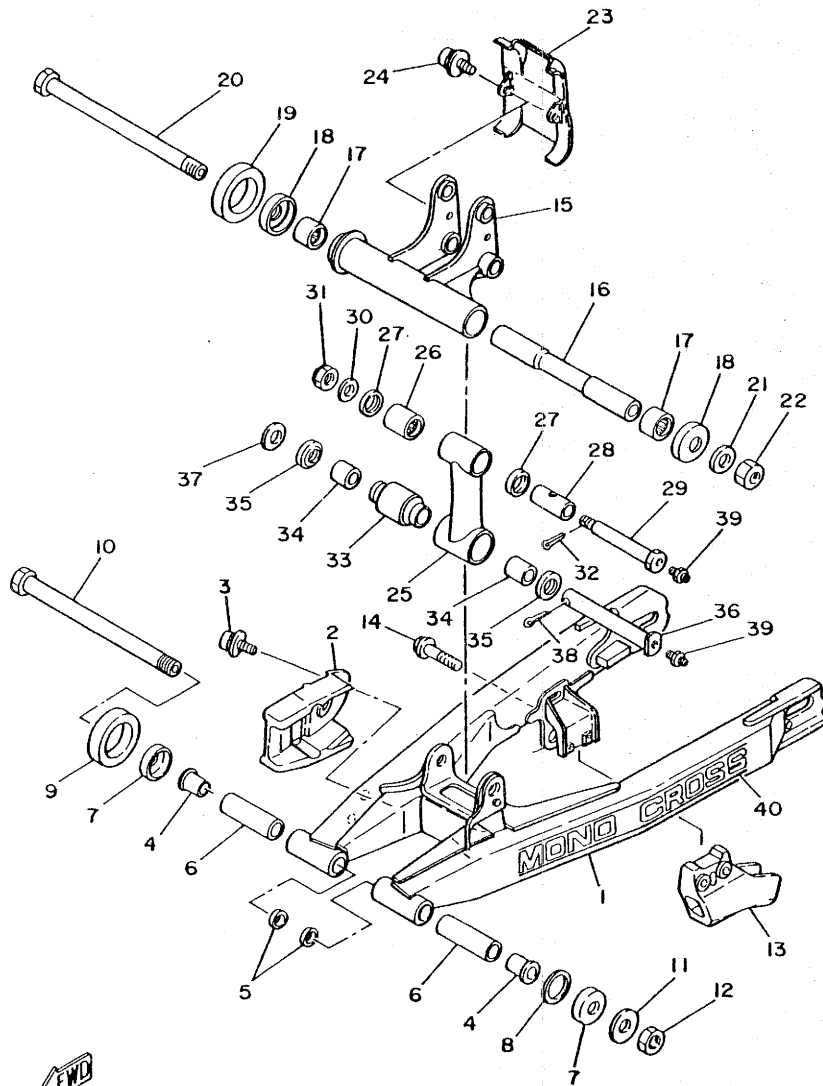

5X3300-3170

REF. NO.	PART NO.	DESCRIPTION	Q'TY	REMARKS
1	5X3-22110-00-35	REAR ARM COMP.	1	silver
2	5X3-22147-00	PROTECTOR, chain	1	
3	90159-05026	SCREW, with washer	2	
4	3Y1-22184-01	BUSH	2	
5	93109-22019	OIL SEAL	2	
6	90380-16098	BUSH, solid	2	
7	322-22128-01	COVER, thrust 1	2	
8	156-22127-00	SHIM (0.3T)	1	
9	1W1-22151-00	SEAL, Guard	1	
10	5X4-22141-00	SHAFT, Pivot	1	
11	90201-160F6	WASHER, Plate	1	
12	90170-16111	NUT	1	
13	5X4-22199-00	SUPPORT, chain	1	
14	95802-08040	BOLT, flange	2	
15	5X3-2217A-00	ARM, relay	1	
16	90387-163F6	COLLAR	1	
17	93317-22208	BEARING, cylindrical	2	
18	322-22128-01	COVER, thrust 1	2	
19	1W1-22151-00	SEAL, Guard	1	
20	5X4-22141-00	SHAFT, Pivot	1	
21	90201-160F6	WASHER, Plate	1	
22	90170-16111	NUT	1	
23	5X3-21652-00	PROTECTOR	1	
24	90159-05026	SCREW, with washer	2	
25	5X3-2217F-00	ROD, connecting 1	1	
26	93317-22023	BEARING, cylindrical	1	
27	93109-20029	OIL SEAL	2	
28	90380-14095	BUSH, solid	1	

C7

FIG. 17 REAR ARM

REF. NO.	PART NO.	DESCRIPTION	Q'TY	REMARKS
29	90109-12646	BOLT	1	
30	90201-120E6	WASHER, Plate	1	
31	90185-12061	NUT, self-locking	1	
32	91401-25020	PIN, cotter	1	
33	5X6-22123-00	BUSH 1	1	
34	90384-16156	BUSH, bimetal formed	2	
35	5X6-2217H-00	COVER, dust	2	
36	90249-16154	PIN	1	
37	90201-16243	WASHER, Plate	1	
38	91401-40030	PIN, cotter	1	
39	93700-06004	NIPPLE, Grease	2	
40	5X3-2218A-00	EMBLEM, rear arm	2	

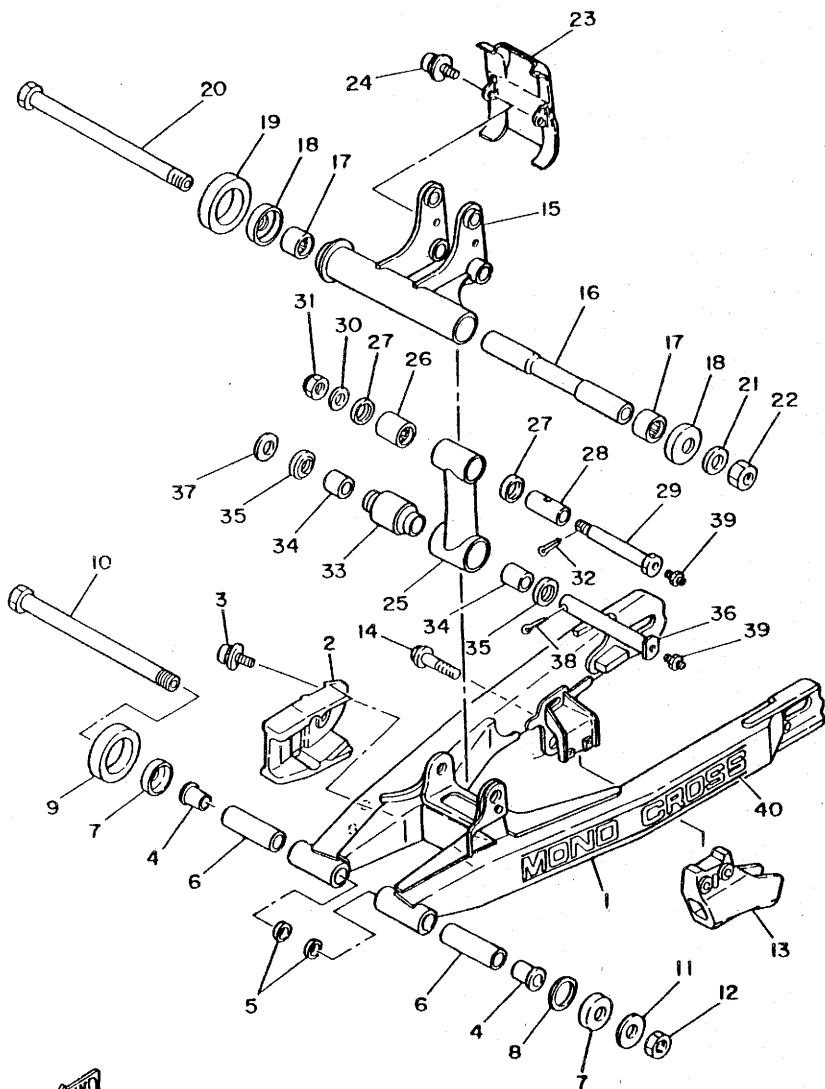

5X3300-3170

C8

FIG. 18 REAR SUSPENSION

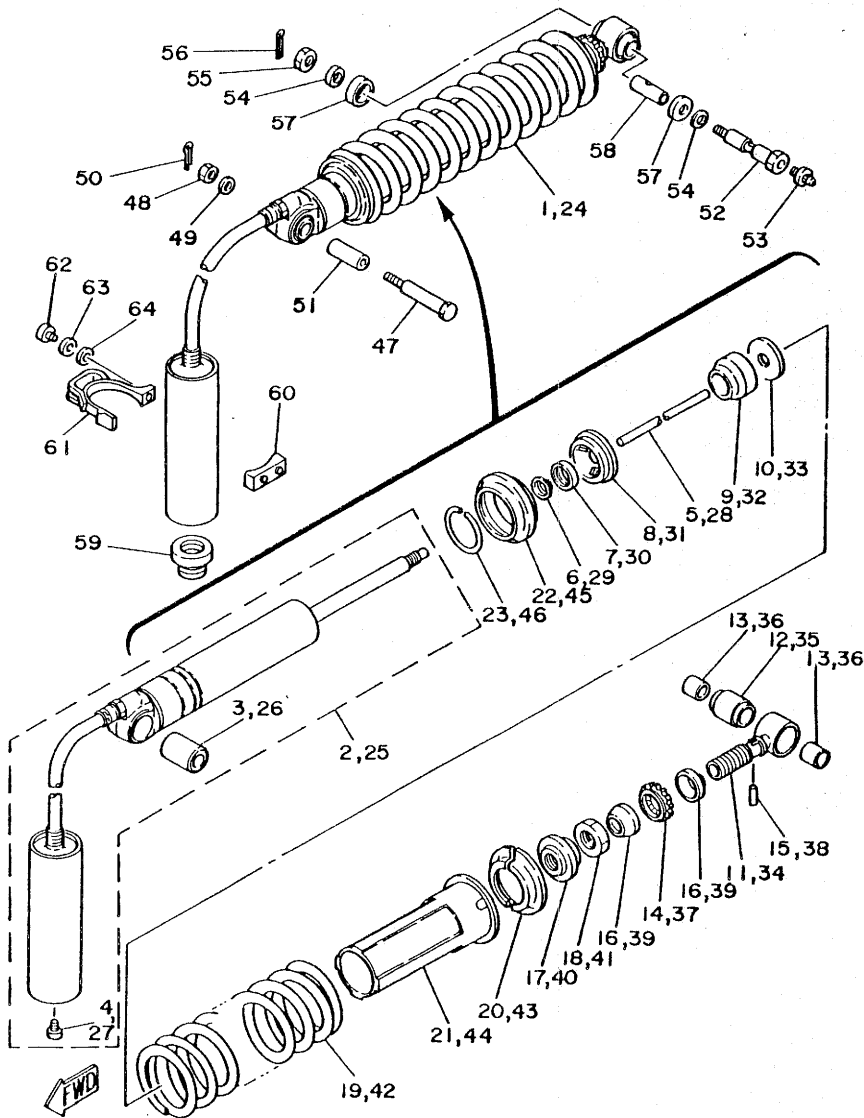

5X3300-3180

REF. NO.	PART NO.	DESCRIPTION	Q'TY	REMARKS
1	5X3-22210-10-6W	SHOCK ABSORBER ASSY, rear	1	UR for europe
2	5X3-22401-10	•DUMPER SUB ASSY	1	
3	5X6-22216-00	••BUSH, rear shock absorber	1	
4	98501-04005	••SCREW, Pan head	1	
5	5X3-22489-00	•ROD, Push	1	
6	3R4-22475-00	•SEAL, dust	1	
7	3R4-22473-00	•HOUSING, seal ring	1	
8	4L0-22472-00	•CAP, case	1	
9	5X3-22493-00	•BUMP, stop	1	
10	3R4-22228-00	•SUPPORT, bumP stop	1	
11	5X3-22409-00	•UPPER BRACKET SUB ASSY	1	
12	5X6-22226-00	•BUSH, shock absorber lower	1	
13	90384-18157	•BUSH, bimetal formed	2	
14	5X3-22497-00	•NUT, adjusting	1	
15	93604-26132	•PIN, dowel	1	
16	3R4-22221-01	•COVER	2	
17	3R4-22213-00	•SEAT, sPrinG upper	1	
18	90170-20213	•NUT	1	
19	5X3-22212-00-6W	•SPRING	1	
20	3R4-22214-00	•GUIDE, sPrinG 1	2	
21	5X3-22224-00	•GUIDE, sPrinG 2	1	
22	3R4-22223-00	•SEAT, sPrinG lower	1	
23	93440-50078	•CIRCLIP	1	
24	5X3-22210-00-6W	SHOCK ABSORBER ASSY, rear	1	UR
25	5X3-22401-00	•DUMPER SUB ASSY	1	
26	5X6-22216-00	••BUSH, rear shock absorber	1	
27	98501-04005	••SCREW, Pan head	1	
28	5X3-22489-00	•ROD, Push	1	

C9

FIG. 18 REAR SUSPENSION

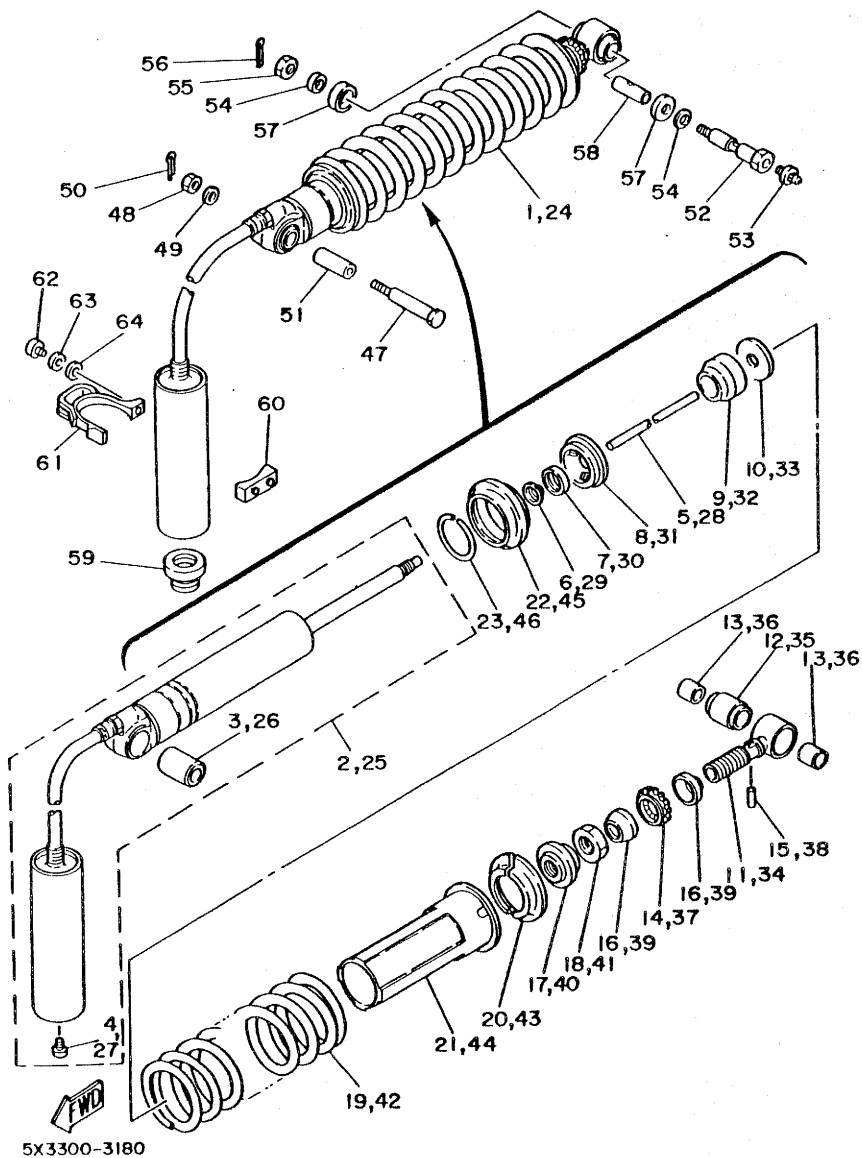

REF. NO.	PART NO.	DESCRIPTION	Q'TY	REMARKS
29	3R4-22475-00	.SEAL, dust	1	
30	3R4-22473-00	.HOUSING, seal ring	1	
31	4L0-22472-00	.CAP, case	1	
32	5X3-22493-00	.BUMP, stop	1	
33	3R4-22228-00	.SUPPORT, bump stop	1	
34	5X3-22409-00	.UPPER BRACKET SUB ASSY	1	
35	5X6-22226-00	.BUSH, shock absorber lower	1	
36	90384-18157	.BUSH, bimetal formed	2	
37	5X3-22497-00	.NUT, adjusting	1	
38	93604-26132	.PIN, dowel	1	
39	3R4-22221-01	.COVER	2	
40	3R4-22213-00	.SEAT, spring upper	1	
41	90170-20213	.NUT	1	
42	5X3-22212-00-6W	.SPRING	1	
43	3R4-22214-00	.GUIDE, spring 1	2	
44	5X3-22224-00	.GUIDE, spring 2	1	
45	3R4-22223-00	.SEAT, spring lower	1	
46	93440-50078	.CIRCLIP	1	
47	90109-10550	BOLT	1	
48	95302-10700	NUT	1	
49	90201-10430	WASHER, Plate	1	
50	91401-20020	PIN, cotter	1	
51	90380-12094	BUSH, solid	1	
52	90109-10648	BOLT	1	
53	93700-06004	NIPPLE, Grease	1	
54	90201-100E9	WASHER, Plate	2	
55	95601-10100	NUT, u	1	
56	91401-25020	PIN, cotter	1	

FIG. 18 REAR SUSPENSION

REF. NO.	PART NO.	DESCRIPTION	Q'TY	REMARKS
57	5X6-22129-00	COVER, thrust 2	2	
58	90380-12094	BUSH, solid	1	
59	90480-22263	GROMMET	1	
60	5X4-22261-00	DAMPER, sub tank	1	
61	3R3-22262-00	HOLDER, sub tank	1	
62	92502-06016	SCREW, Pan head	1	
63	92902-06100	WASHER, sPrin&	1	
64	92902-06600	WASHER	1	

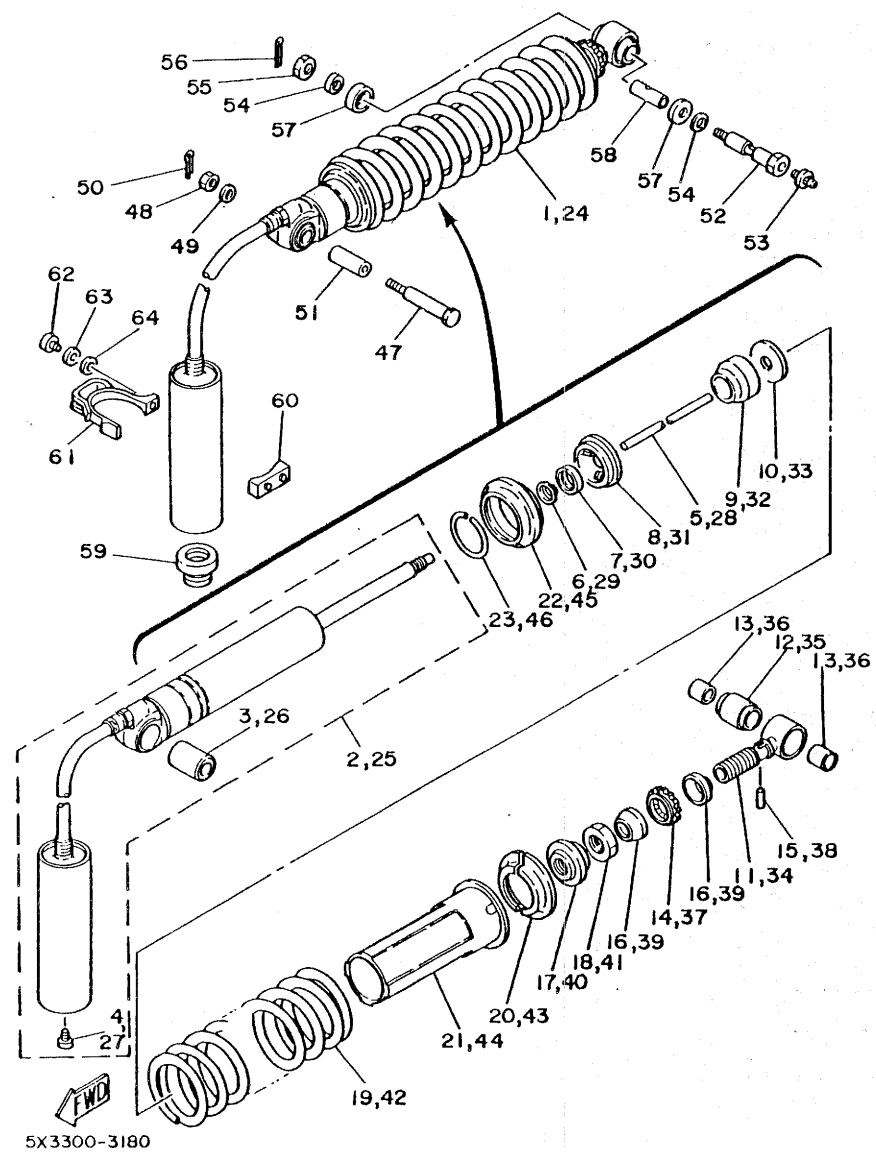

C11

FIG. 19 STEERING

REF. NO.	PART NO.	DESCRIPTION	Q'TY	REMARKS
1	5X3-23435-01-98	CROWN, handle	1	low gloss black
2	95821-08040	BOLT, flange	4	
3	95821-08055	BOLT, flange	1	
4	95701-08100	NUT, flange	1	
5	90105-14102	BOLT, washer based	1	
6	1E6-23441-00-98	HOLDER, handle upper	2	low gloss black
7	95821-08035	BOLT, flange	4	
8	93332-00023	BEARING	1	
9	93332-00008	BEARING	1	
10	1W1-23416-00	COVER, ball race 2	1	
11	90179-25033	NUT	1	
12	5X6-23485-11	PLATE, number	1	
13	90387-065F7	COLLAR	1	
14	90201-06571	WASHER, Plate	1	
15	92501-06015	SCREW, Pan head	1	
16	5X6-23395-10	EMBLEM	1	

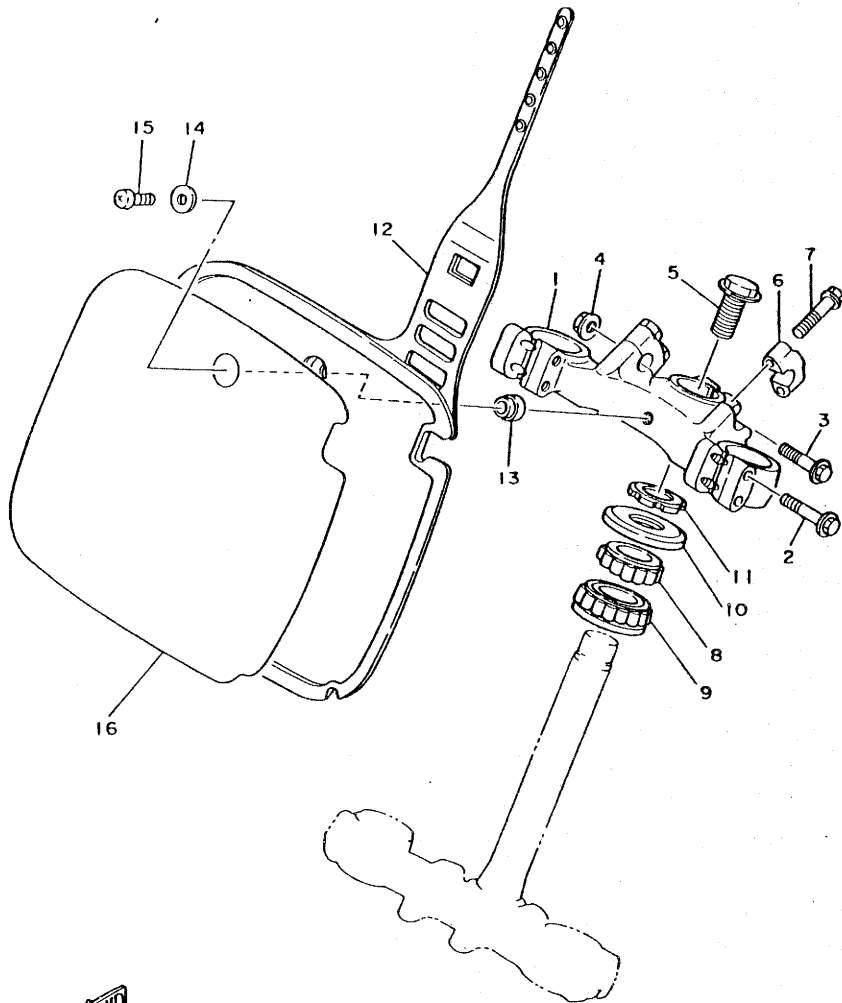

5X3300-3190

C12

FIG. 20 FRONT FORK

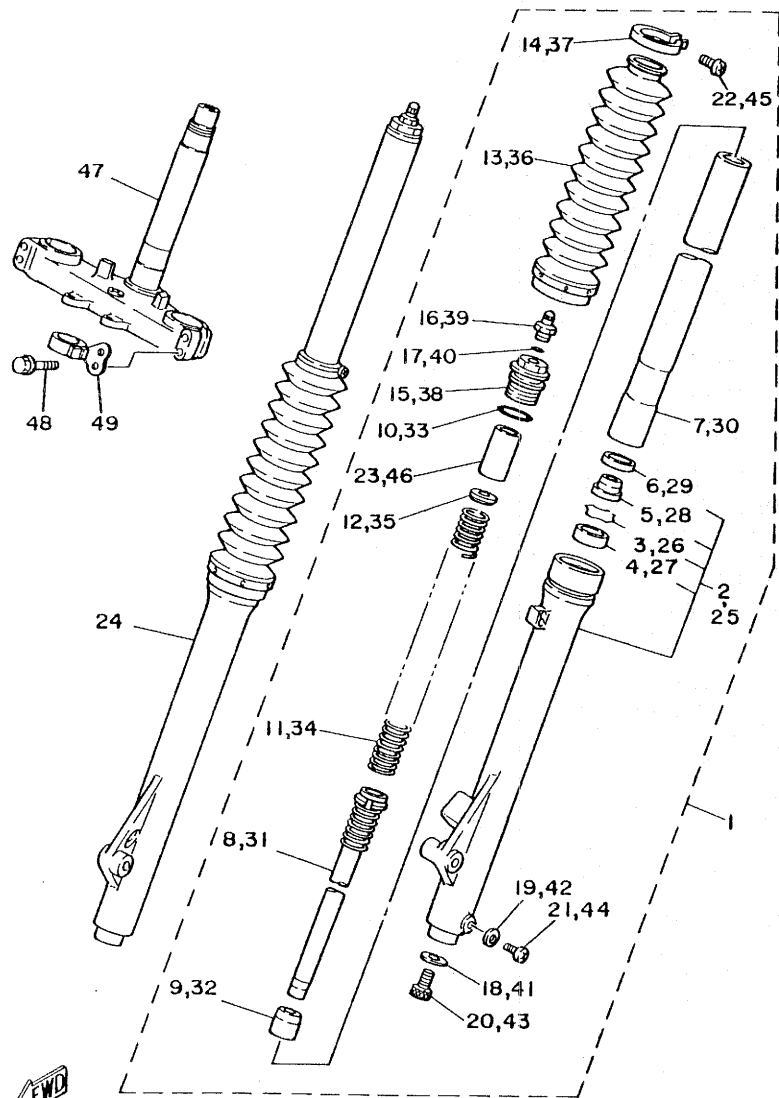

REF. NO.	PART NO.	DESCRIPTION	Q'TY	REMARKS
1	5X3-23102-M0	FRONT FORK ASSY (L.H)	1	
2	5X3-23126-L0	.TUBE, outer 1	1	
3	4A1-23156-00	..CLIP, oil seal	1	
4	1W1-23145-L0	..OIL SEAL	1	
5	3R8-23144-L0	..SEAL, dust	1	
6	3R8-23148-L0	..COVER, dust seal	1	
7	5X3-23110-L0	.INNER TUBE COMP.1	1	
8	3R6-23170-L0	.CYLINDER COMP., front fork	1	
9	3R6-23173-L0	.SPINDLE, taPer	1	
10	1W1-23114-L0	.GASKET	1	
11	5X3-23141-L0	.SPRING, front fork	1	
12	1W1-23142-L0	.SEAT, sPring uPPer	1	
13	5X3-23191-M0	.BOOT	1	
14	341-92090-60	.BAND, boot	1	
15	5X3-23111-L0	.BOLT, caP	1	
16	4V4-23190-L0	.AIR VALVE COMP.	1	
17	3J2-23147-00	.O-RING	1	
18	509-23158-L0	.GASKET	1	
19	122-23129-00	.GASKET, drain Plug	1	
20	278-23181-50	.BOLT, hexaGon socket head	1	
21	122-23119-01	.PLUG, drain	1	
22	4V2-23194-L0	.SCREW, boot band	1	
23	4V5-23118-L1	.SPACER	1	
24	5X3-23103-M0	FRONT FORK ASSY (R.H)	1	
25	5X3-23136-L0	.TUBE, outer 2	1	
26	4A1-23156-00	..CLIP, oil seal	1	
27	1W1-23145-L0	..OIL SEAL	1	
28	3R8-23144-L0	..SEAL, dust	1	

5X3100-2200

C13

FIG. 20 FRONT FORK

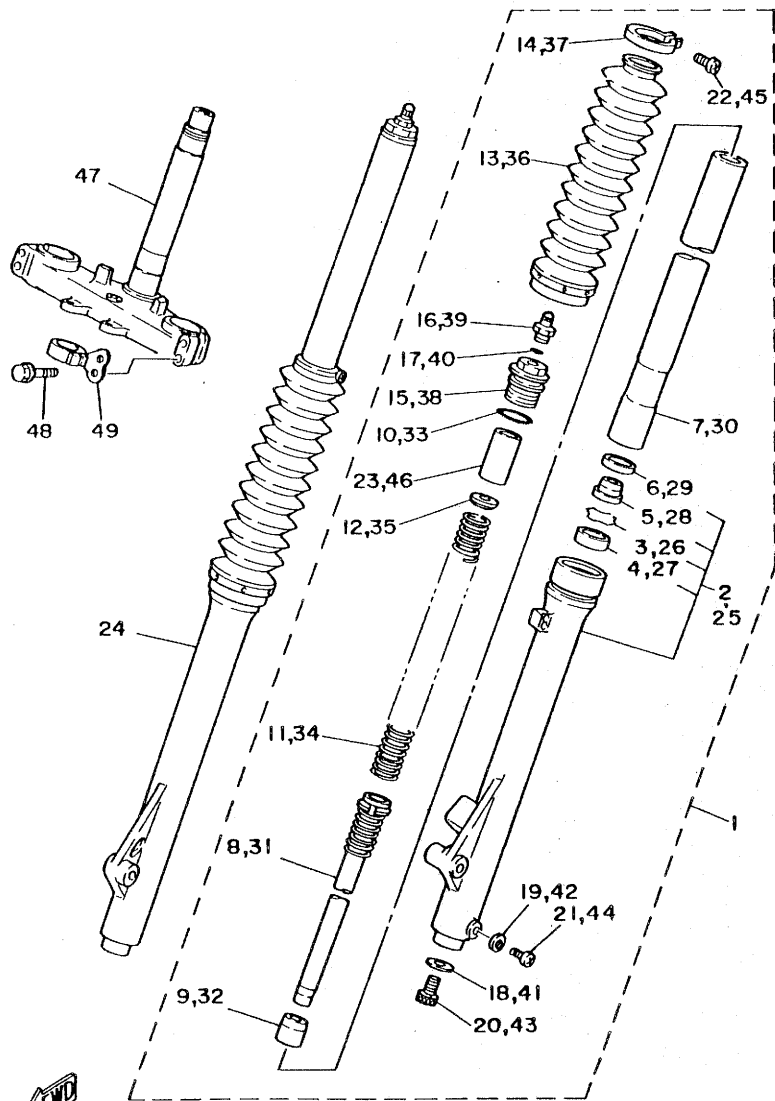

5X3100-2200

C14

REF. NO.	PART NO.	DESCRIPTION	Q'TY	REMARKS
29	3R8-23148-L0	•COVER, dust seal	1	
30	5X3-23110-L0	•INNER TUBE COMP.1	1	
31	3R6-23170-L0	•CYLINDER COMP., front fork	1	
32	3R6-23173-L0	•SPINDLE, taPer	1	
33	1W1-23114-L0	•GASKET	1	
34	5X3-23141-L0	•SPRING, front fork	1	
35	1W1-23142-L0	•SEAT, sPrinG uPPer	1	
36	5X3-23191-M0	•BOOT	1	
37	341-92090-60	•BAND, boot	1	
38	5X3-23111-L0	•BOLT, caP	1	
39	4V4-23190-L0	•AIR VALVE COMP.	1	
40	3J2-23147-00	•O-RING	1	
41	509-23158-L0	•GASKET	1	
42	122-23129-00	•GASKET, drain Plug	1	
43	278-23181-50	•BOLT, hexaGon socket head	1	
44	122-23119-01	•PLUG, drain	1	
45	4V2-23194-L0	•SCREW, boot band	1	
46	4V5-23118-L1	•SPACER	1	
47	5X3-23340-L0-33	UNDER BRACKET COMP.	1	yamaha black
48	5X3-23181-L0	BOLT, hexaGon socket head	1	
49	3R4-23389-00	GUIDE, cable	1	

FIG. 21 FUEL TANK

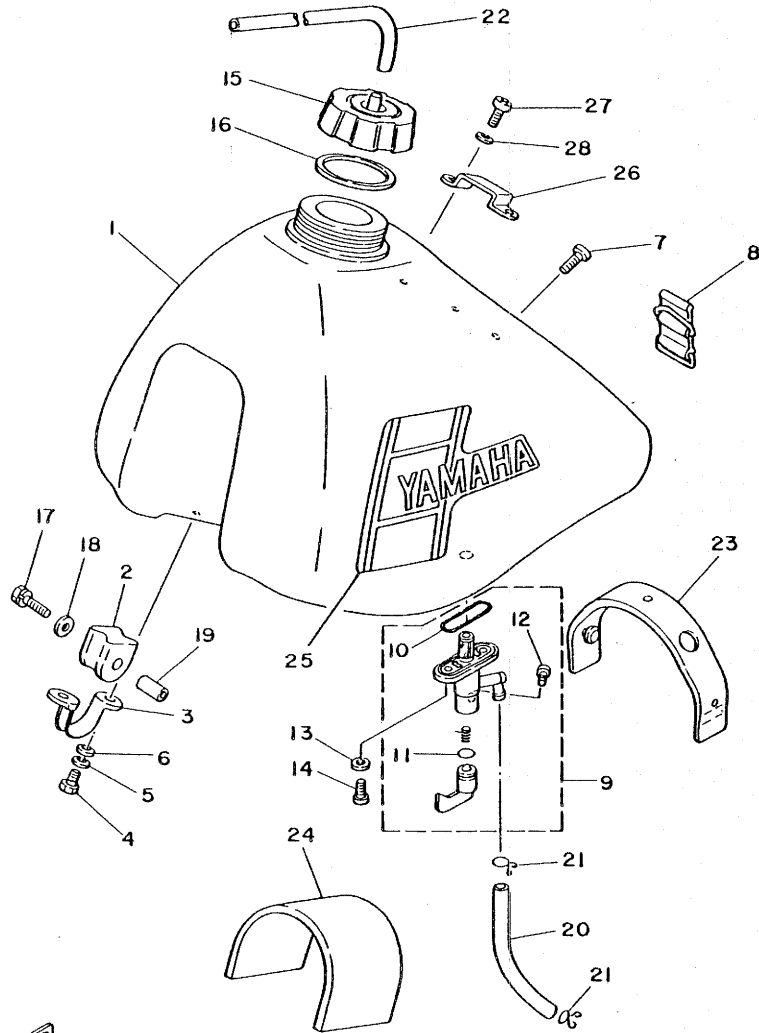

REF. NO.	PART NO.	DESCRIPTION	Q'TY	REMARKS
1	5X4-24110-10	FUEL TANK COMP.	1	white
2	1W1-24182-01	DAMPER, locatin& 2	2	
3	1W1-24144-01	HOLDER, damPer	2	
4	97301-06012	BOLT	4	
5	92901-06100	WASHER, sPrin&	4	
6	92901-06600	WASHER, Plate	4	
7	98902-06018	SCREW, bind	1	
8	3R3-24173-00	BAND, tank fittin& 1	1	
9	2K5-24500-00	FUEL COCK ASSY 1	1	
10	214-24512-00	.GASKET	1	
11	1A0-24512-00	.O-RING	1	
12	619-24535-00	.SCREW, lever fittin&	1	
13	90202-06010	WASHER, Plate	2	
14	90149-06011	SCREW	2	
15	5X7-24611-01	BODY, caP	1	
16	5X7-24612-00	GASKET, caP	1	
17	90119-06022	BOLT, with washer	2	
18	90201-06407	WASHER, Plate	2	
19	90387-07393	COLLAR	2	
20	90445-11182	HOSE	1	
21	90467-10008	CLIP	2	
22	90445-09300	HOSE	1	
23	3R4-24181-00	DAMPER, locatin& 1	1	
24	1W1-24183-00	DAMPER, locatin& 3	1	
25	5X3-24250-10	GRAPIC SET	1	
26	5X6-2412F-00	BRACKET, seat	1	
27	92501-06012	SCREW, Pan head	2	
28	92901-06100	WASHER, sPrin&	2	

FWD
5X3100-2211

C15

FIG. 22 SEAT

REF. NO.	PART NO.	DESCRIPTION	Q'TY	REMARKS
1	5X4-W2473-10	SEMI-DOUBLE SEAT ASSY	1	
2	5X4-24771-10	COVER, semi-double seat	1	
3	1W1-24738-00	BRACKET, seat	2	
4	90101-06304	BOLT	4	
5	509-24724-00	DAMPER, seat	1	
6	116-24741-00	PAD, seat	2	
7	5X6-24748-00	BRACKET, seat	1	
8	97301-06012	BOLT	2	
9	92901-06100	WASHER, sPring	2	
10	97302-06035	BOLT	2	
11	92902-06600	WASHER	2	
12	95602-06100	NUT, u	2	
13	92902-06100	WASHER, sPring	2	

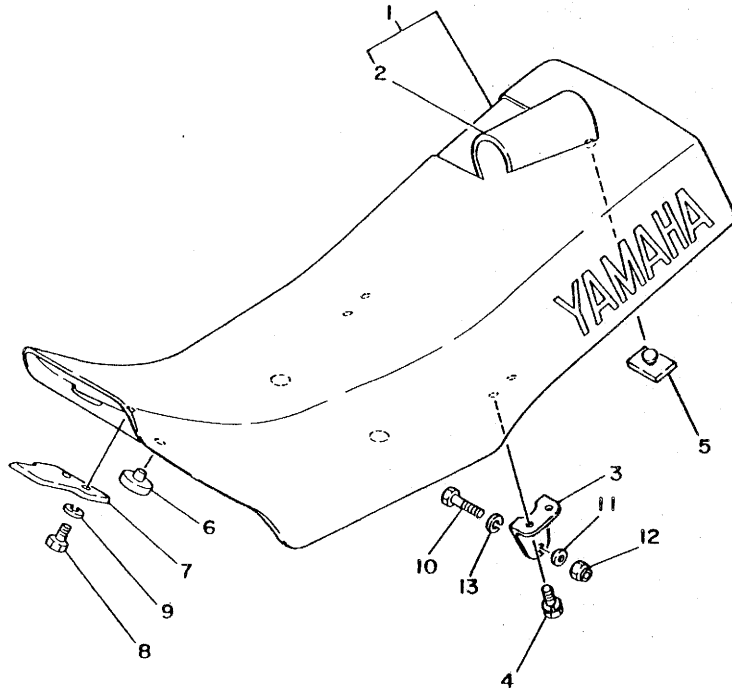

5X3100-2221

D2

FIG. 23 FRONT WHEEL

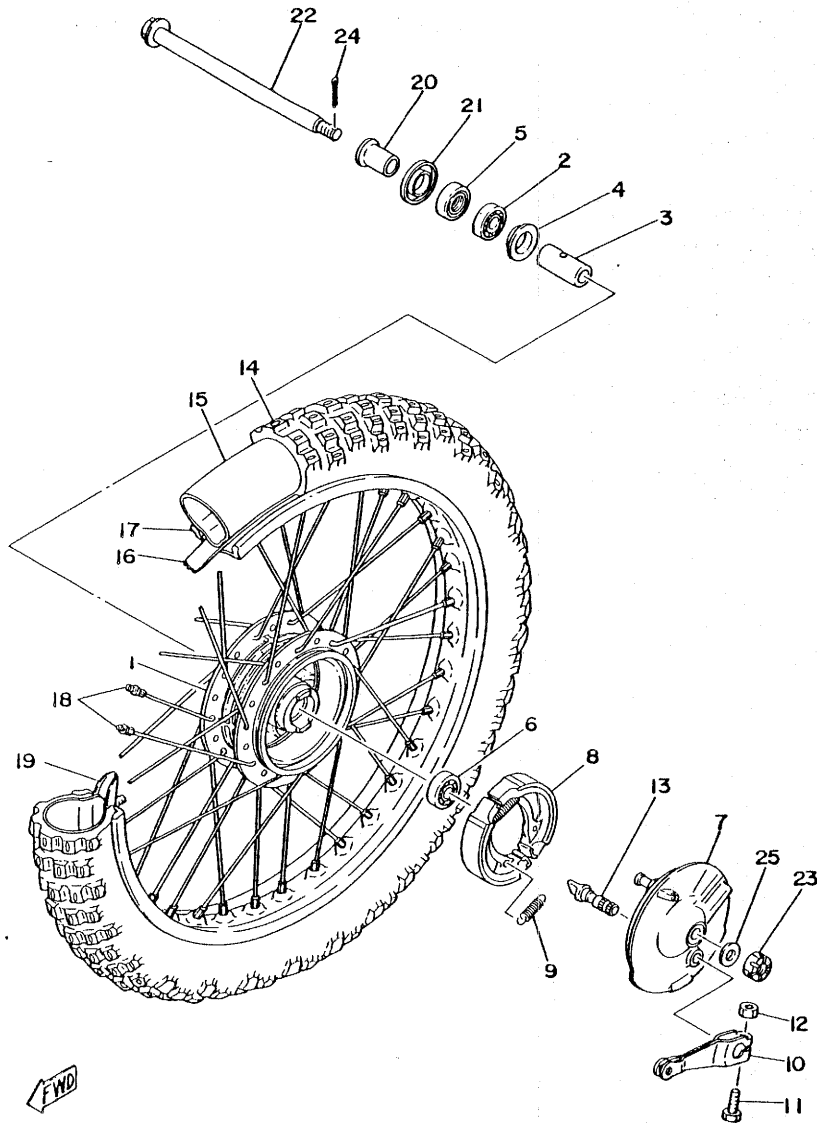

REF. NO.	PART NO.	DESCRIPTION	Q'TY	REMARKS
1	248-25111-00-98	HUB, front	1	low gloss black
2	93306-30102	BEARING (B6301)	1	
3	90560-12138	SPACER	1	
4	109-25315-00	FLANGE, spacer	1	
5	93102-18008	OIL SEAL	1	
6	93306-30103	BEARING (B6301Z)	1	
7	2K5-25121-01-98	PLATE, brake shoe	1	low gloss black
8	5H0-25330-00	BRAKE SHOE COMP.	2	
9	90506-15260	SPRING, tension	2	
10	401-25155-11	LEVER, camshaft 1	1	
11	90101-06278	BOLT	1	
12	95301-06600	NUT	1	
13	122-25351-02	CAMSHAFT	1	
14	94130-21732	TIRE (3.00-21)	1	bridgestone for europe
	94130-21731	TIRE (3.00-21)	1	inoue except europe
15	94227-21123	TUBE (2.75-21)	1	bridgestone for europe
	94230-21126	TUBE (3.00-21)	1	inoue except europe
16	94330-21084	BAND, rim (3.00-21)	1	bridgestone for europe
	94330-21088	BAND, rim (3.00-21)	1	inoue except europe
17	94416-21346	RIM (1.60-21)	1	for europe
	94416-21265	RIM (1.60-21)	1	except europe
18	345-25104-01	SPOKE SET, front	1	
19	1T1-25194-00	SPACER, bead	1	
20	90387-125F8	COLLAR	1	
21	2K5-25118-00	COVER, hub dust	1	
22	4L0-25181-00	AXLE, wheel	1	
23	90171-12005	NUT, castle	1	
24	91401-30025	PIN, cotter	1	

D3

FIG. 23 FRONT WHEEL

REF. NO.	PART NO.	DESCRIPTION	Q'TY	REMARKS
25	90201-12174	WASHER, Plate	1	

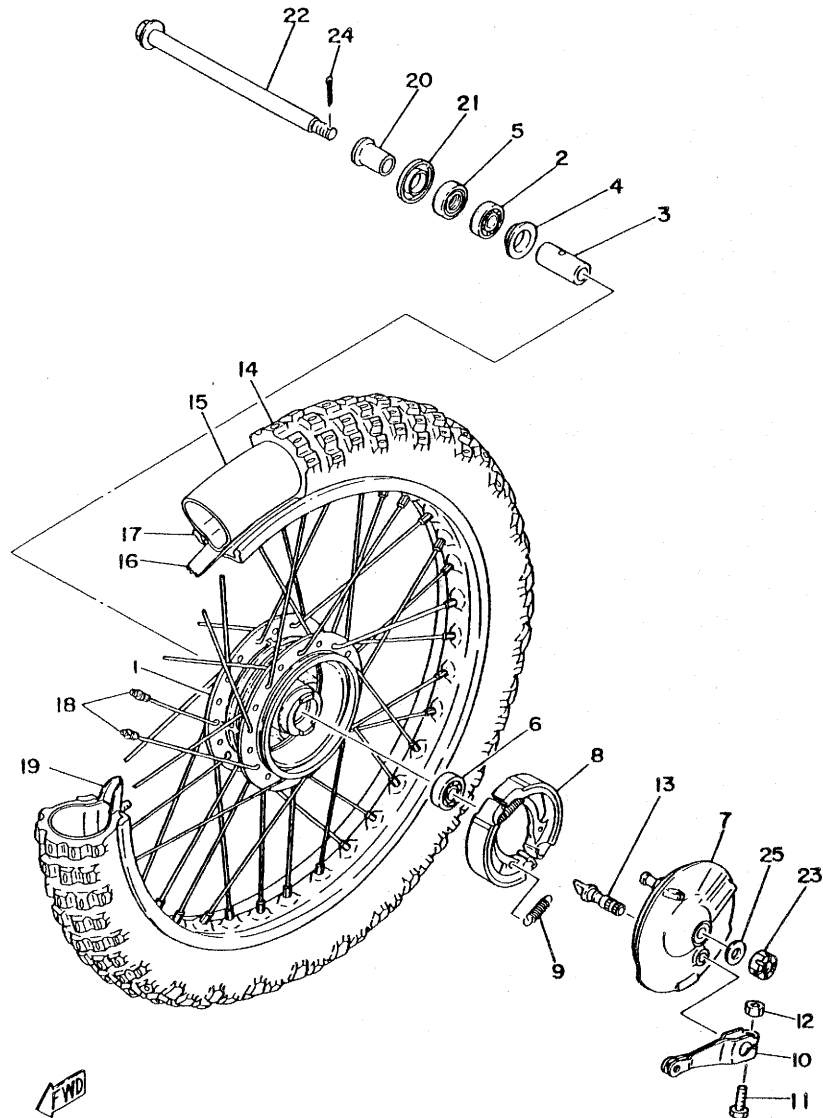

FWD

5X3100-2230

D4

FIG. 24 REAR WHEEL

REF. NO.	PART NO.	DESCRIPTION	Q'TY	REMARKS
1	3R3-25311-02-98	HUB, rear	1	low gloss black
2	3R3-25317-00	SPACER, bearing	1	
3	183-25315-00	FLANGE, spacer	1	
4	93306-20205	BEARING (B6202)	1	
5	93306-30203	BEARING (B6302Z)	1	
6	93106-22017	OIL SEAL	1	
7	3R6-25321-00-98	PLATE, brake shoe	1	low gloss black
8	437-25330-01	BRAKE SHOE COMP.	2	
9	90506-16036	SPRING, tension	2	
10	401-25351-00	CAMSHAFT	1	
11	3R6-25355-01	LEVER, camshaft	1	
12	90101-06278	BOLT	1	
13	95301-06600	NUT	1	
14	148-25359-00	SEAL, camshaft	1	
15	94418-18347	RIM (1.85-18)	1	for europe
	94418-18312	RIM (1.85-18)	1	except europe
16	4V2-25304-00	SPOKE SET, rear	1	
17	94141-18733	TIRE (4.10-18)	1	bridgestone for europe
	94111-18781	TIRE (110/90-18 61M)	1	inoue except europe
18	94241-18153	TUBE (4.10-18)	1	bridgestone for europe
	94235-18085	TUBE (3.50-18)	1	inoue except europe
19	94330-18087	BAND, rim (3.00-18)	1	bridgestone for europe
	94325-18043	BAND, rim (2.50-18)	1	inoue except europe
20	2X3-25394-00	SPACER, bead	2	
21	3R4-25450-00	SPROCKET, driven (50T)	1	UR STD
	3R4-25446-00	SPROCKET, driven (46T)	1	AP
	3R4-25448-00	SPROCKET, driven (48T)	1	AP
	3R4-25452-00	SPROCKET, driven (52T)	1	AP

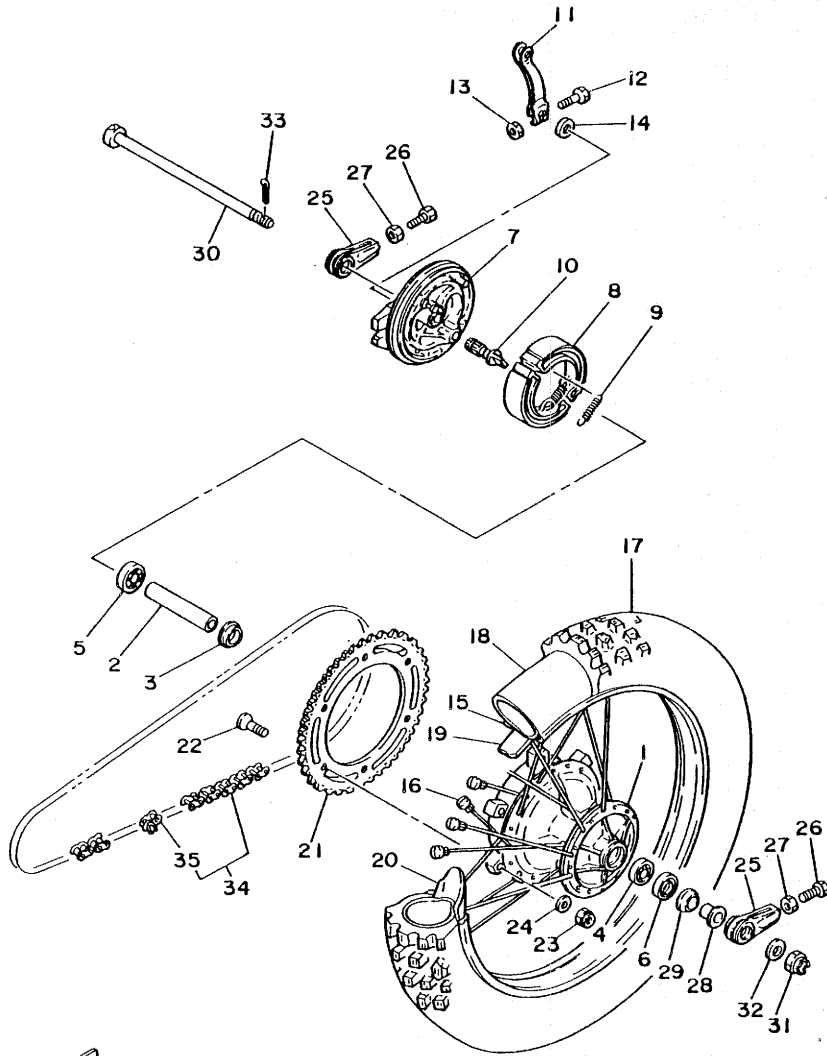

5X3100-2240

D5

FIG. 24 REAR WHEEL

REF. NO.	PART NO.	DESCRIPTION	Q'TY	REMARKS
22	90110-08038	BOLT, hexagon socket head	6	
23	90185-08089	NUT, self-locking	6	
24	92901-08200	WASHER, Plain	6	
25	537-25388-00	PULLER, chain 1	2	
26	90101-08034	BOLT	2	
27	95301-08700	NUT	2	
28	90387-15791	COLLAR	1	
29	3R3-25367-00	COVER, hub dust	1	
30	5X3-25381-00	AXLE, wheel	1	
31	90171-14020	NUT, castle	1	
32	90201-15238	WASHER, Plate	1	
33	91401-30030	PIN, cotter	1	
34	94585-20106	CHAIN (DID520DS-106L)	1	
35	94685-20001	JOINT, chain	1	

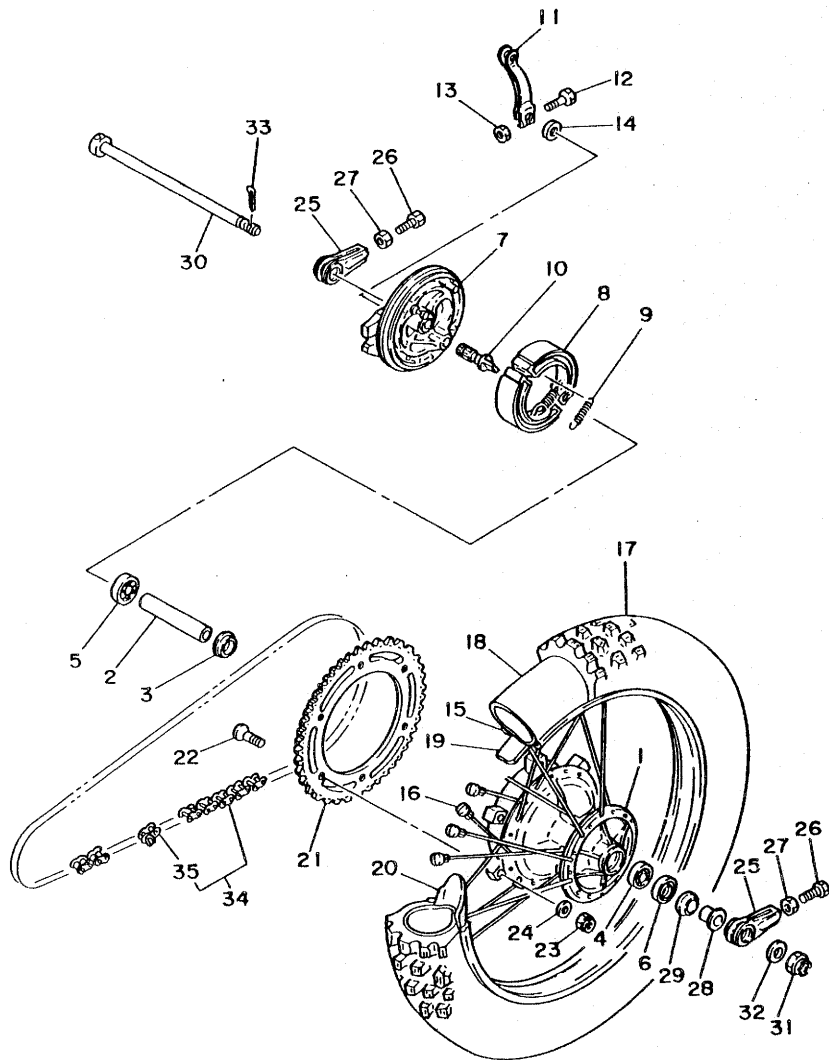

5X3100-2240

D6

FIG. 25 HANDLEBAR·CABLE

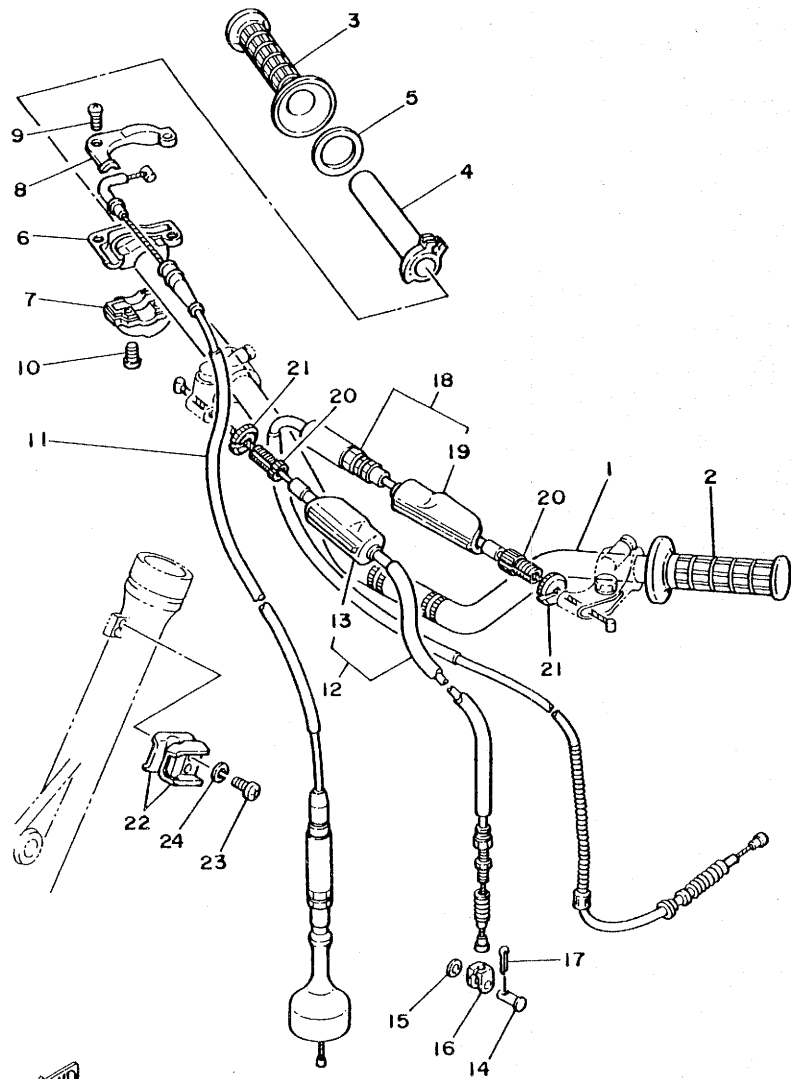

REF. NO.	PART NO.	DESCRIPTION	Q'TY	REMARKS
1	5X3-26111-00	HANDLEBAR	1	
2	4V4-26241-00	GRIP (L.H)	1	
3	3R9-26242-00	GRIP (R.H)	1	
4	322-26243-00	TUBE, throttle guide	1	
5	1W1-26249-00	RING, leaf	1	
6	5X2-26281-00	CAP, grip upper	1	
7	322-26282-00-98	CAP, grip lower	1	low gloss black
8	5X2-2628H-01	CAP, wire	1	
9	98606-04012	SCREW, oval head	2	
10	98506-05016	SCREW, Pan head	2	
11	5X3-26311-00	CABLE, throttle 1	1	
12	5X3-26341-00	CABLE, brake	1	
13	382-26372-01	COVER, handle lever 1	1	
14	90240-08012	PIN, clevis	1	
15	90201-08083	WASHER, Plate	1	
16	156-26347-00	JOINT, cable	1	
17	91401-20015	PIN, cotter	1	
18	5X3-26335-00	CABLE, clutch	1	
19	382-26372-01	COVER, handle lever 1	1	
20	90123-08046	BOLT	2	
21	90179-08148	NUT	2	
22	90465-14192	CLAMP	2	
23	92501-06015	SCREW, Pan head	2	
24	92901-06100	WASHER, sPring	2	



5X3100-2250

D7

FIG. 26 STAND, FOOTREST

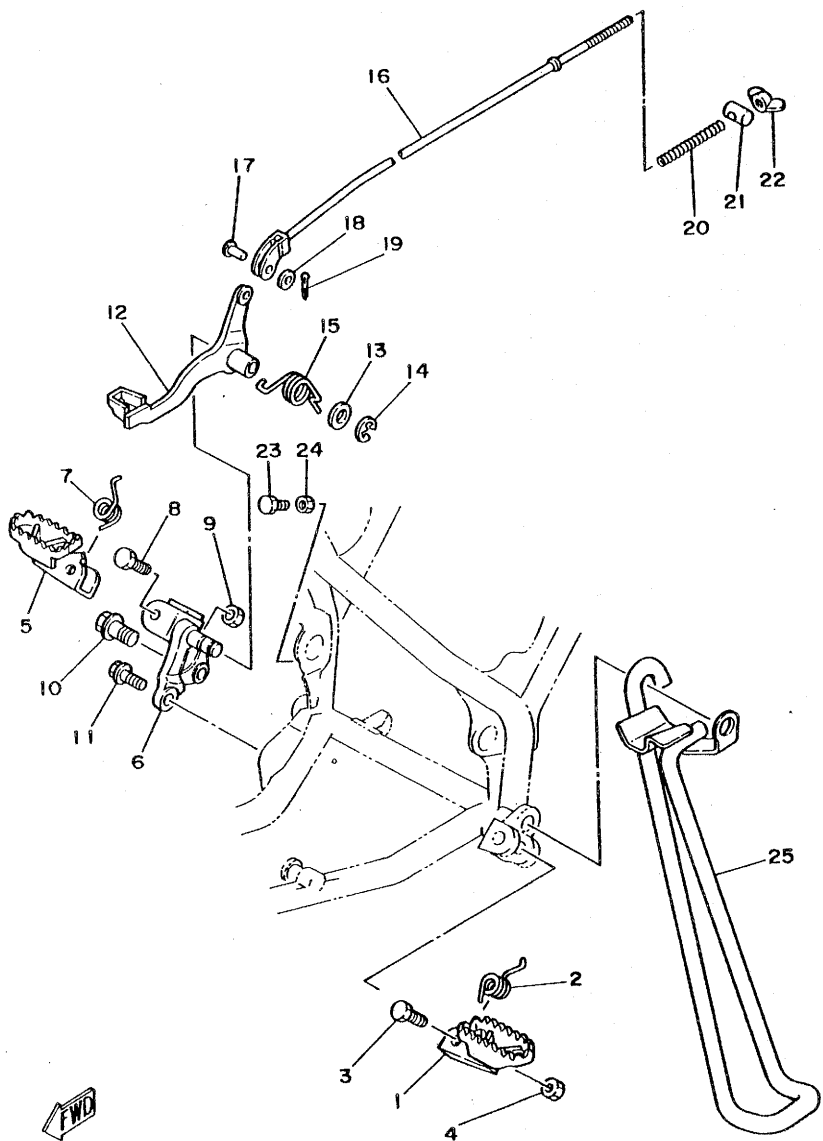

REF. NO.	PART NO.	DESCRIPTION	Q'TY	REMARKS
1	5X3-27411-00	FOOTREST 1	1	
2	90508-20023	SPRING, torsion	1	
3	90101-08428	BOLT	1	
4	95601-08100	NUT, u	1	
5	4V4-27421-00	FOOTREST 2	1	
6	5X3-27422-00	BRACKET, footrest 2	1	
7	90508-20023	SPRING, torsion	1	
8	90101-08428	BOLT	1	
9	95601-08100	NUT, u	1	
10	90105-12096	BOLT, washer based	1	
11	95811-10020	BOLT, flange	1	
12	5X3-27211-00-90	PEDAL, brake	1	uni chrome (black)
13	92902-12200	WASHER	1	
14	93430-09038	CIRCLIP	1	
15	90508-32544	SPRING, torsion	1	
16	5X3-27231-00	ROD, brake	1	
17	90240-06040	PIN, clevis	1	
18	92901-06200	WASHER, Plain	1	
19	91401-20015	PIN, cotter	1	
20	90501-10245	SPRING, compression	1	
21	90249-12008	PIN	1	
22	90175-06013	NUT, wing	1	
23	97301-06020	BOLT	1	
24	95301-06700	NUT	1	
25	5X3-27311-00	STAND, side	1	

FWD
5X3100-2260

D8

FIG. 27 ELECTRICAL 1

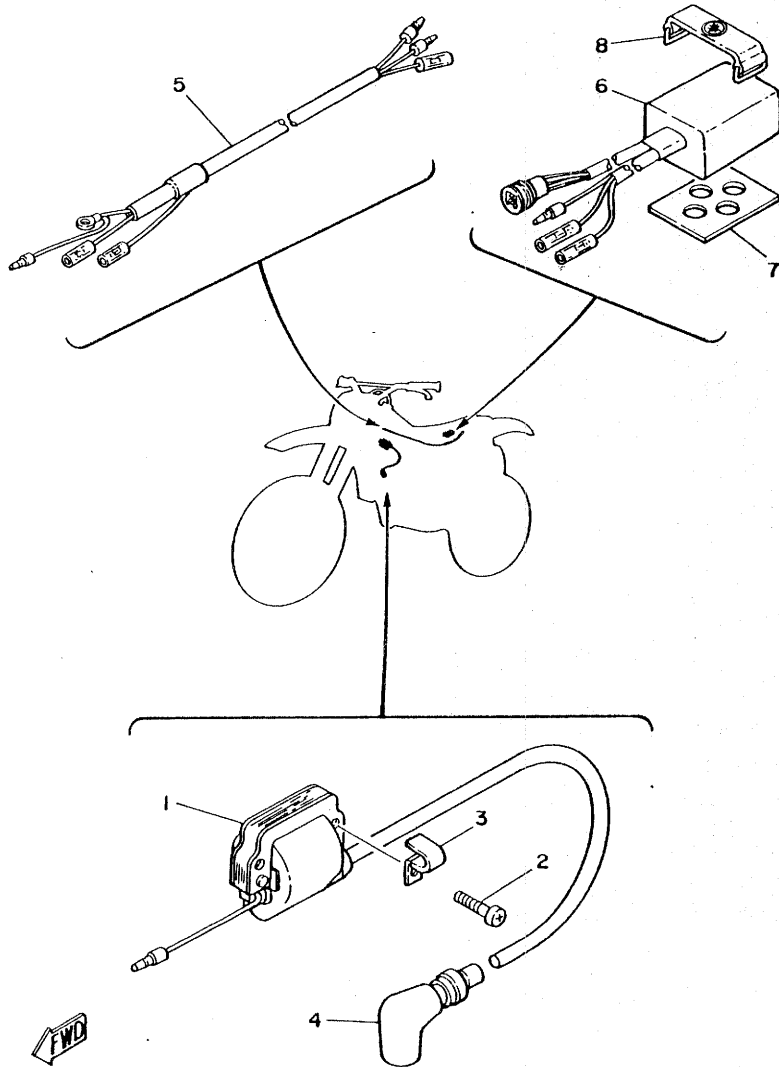

REF. NO.	PART NO.	DESCRIPTION	Q'TY	REMARKS
1	2K7-82310-10	IGNITION COIL ASSY	1	
2	92501-06020	SCREW, Pan head	2	
3	90462-05005	CLAMP	1	
4	3R0-82370-20	PLUG CAP ASSY	1	
5	5X3-82590-00	WIRE HARNESS ASSY	1	
6	5X2-85540-10	C.D.I. UNIT ASSY	1	
7	2K7-85547-00	DAMPER	1	
8	288-21376-00	BAND, tool	1	

5X3100-2271

D9

FIG. 28 HANDLE SWITCH-LEVER

REF. NO.	PART NO.	DESCRIPTION	Q'TY	REMARKS
1	4V4-82911-00	HOLDER, lever 1	1	
2	4V4-82913-00	HOLDER, lever lower 1	1	
3	3M2-83912-00	LEVER 1	1	
4	90201-08083	WASHER, Plate	1	
5	90109-06410	BOLT	1	
6	95601-06100	NUT, u	1	
7	98506-05020	SCREW, Pan head	2	
8	92906-05100	WASHER, sPring	2	
9	4V4-82921-00	HOLDER, lever 2	1	
10	4V4-82913-00	HOLDER, lever lower 1	1	
11	3M2-83922-00	LEVER 2	1	
12	90201-08083	WASHER, Plate	1	
13	90109-06410	BOLT	1	
14	95601-06100	NUT, u	1	
15	98506-05020	SCREW, Pan head	2	
16	92906-05100	WASHER, sPring	2	
17	3R4-83976-00	SWITCH, handle 1	1	
18	437-83936-00	BAND, switch cord	2	

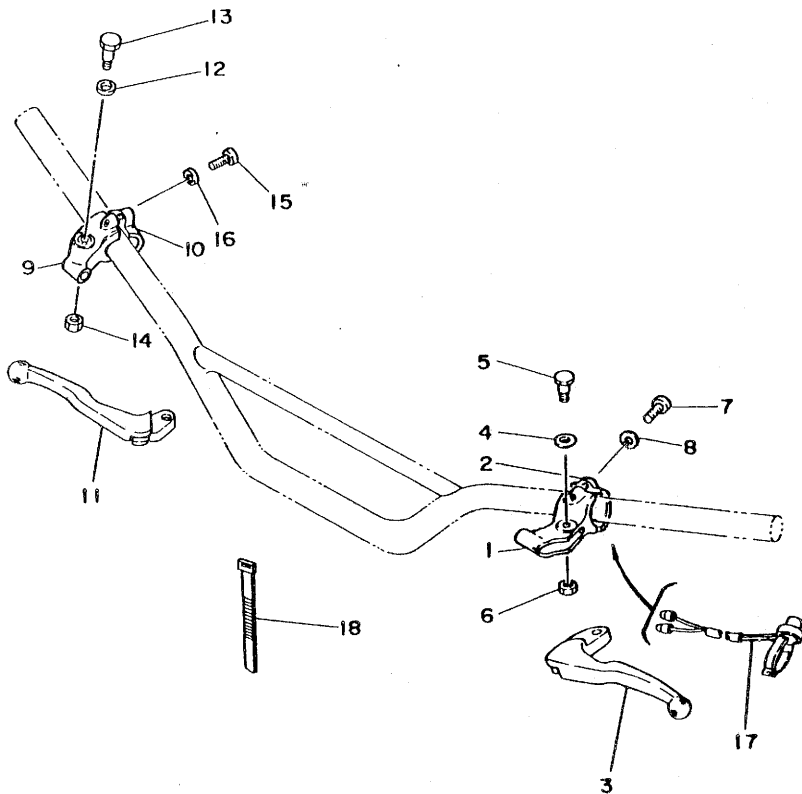

5X4100-2310

D10



REPAIR KIT

FIG. 29 REPAIR KIT

REF. NO.	PART NO.	DESCRIPTION	Q'TY	REMARKS
1	5X3-11630-01	PISTON ASSY (STD)	1	
2	5X3-11631-01-97	•PISTON (STD)	1	
3	5X3-11611-00	•RING, Piston	1	
4	1J4-11633-00	•PIN, Piston	1	
5	4V2-11634-00	•CLIP, Piston Pin	2	
6	5X3-11630-11	PISTON ASSY (1ST O/S)	1	
7	5X3-11635-01	•PISTON (1ST O/S 0.25MM)	1	
8	5X3-11611-10	•RING, Piston	1	
9	1J4-11633-00	•PIN, Piston	1	
10	4V2-11634-00	•CLIP, Piston Pin	2	
11	5X3-11630-21	PISTON ASSY (2ND O/S)	1	
12	5X3-11636-01	•PISTON (2ND O/S 0.50MM)	1	
13	5X3-11611-20	•RING, Piston	1	
14	1J4-11633-00	•PIN, Piston	1	
15	4V2-11634-00	•CLIP, Piston Pin	2	
16	5X3-11630-31	PISTON ASSY (3RD O/S)	1	
17	5X3-11637-01	•PISTON (3RD O/S 0.75MM)	1	
18	5X3-11611-30	•RING, Piston	1	
19	1J4-11633-00	•PIN, Piston	1	
20	4V2-11634-00	•CLIP, Piston Pin	2	
21	5X3-11630-41	PISTON ASSY (4TH O/S)	1	
22	5X3-11638-01	•PISTON (4TH O/S 1.00MM)	1	
23	5X3-11611-40	•RING, Piston	1	
24	1J4-11633-00	•PIN, Piston	1	
25	4V2-11634-00	•CLIP, Piston Pin	2	
26	4V2-11650-00	CONNECTING ROD ASSY	1	
27	4V2-11651-00	•ROD, connectin	1	

FIG. 29 REPAIR KIT

REF. NO.	PART NO.	DESCRIPTION	Q'TY	REMARKS
28	3M5-11681-00	.PIN, crank 1	1	
29	90209-22071	.WASHER	2	
30	93310-422H0	.BEARING, cylindrical	1	
31	93310-216J2	.BEARING, cylindrical	1	
32	5X3-W0001-00	GASKET KIT	1	
33	5X3-11181-00	.GASKET, cylinder head 1	1	
34	4V2-11351-00	.GASKET, cylinder	1	
35	10V-13621-00	.GASKET, valve seat	1	
36	3R3-14613-00	.GASKET, exhaust Pipe	1	
37	90430-12038	.GASKET	1	
38	93210-14104	.O-RING	1	
39	4V2-15455-00	.GASKET 1	1	
40	3R3-15451-01	.GASKET, crankcase cover	1	

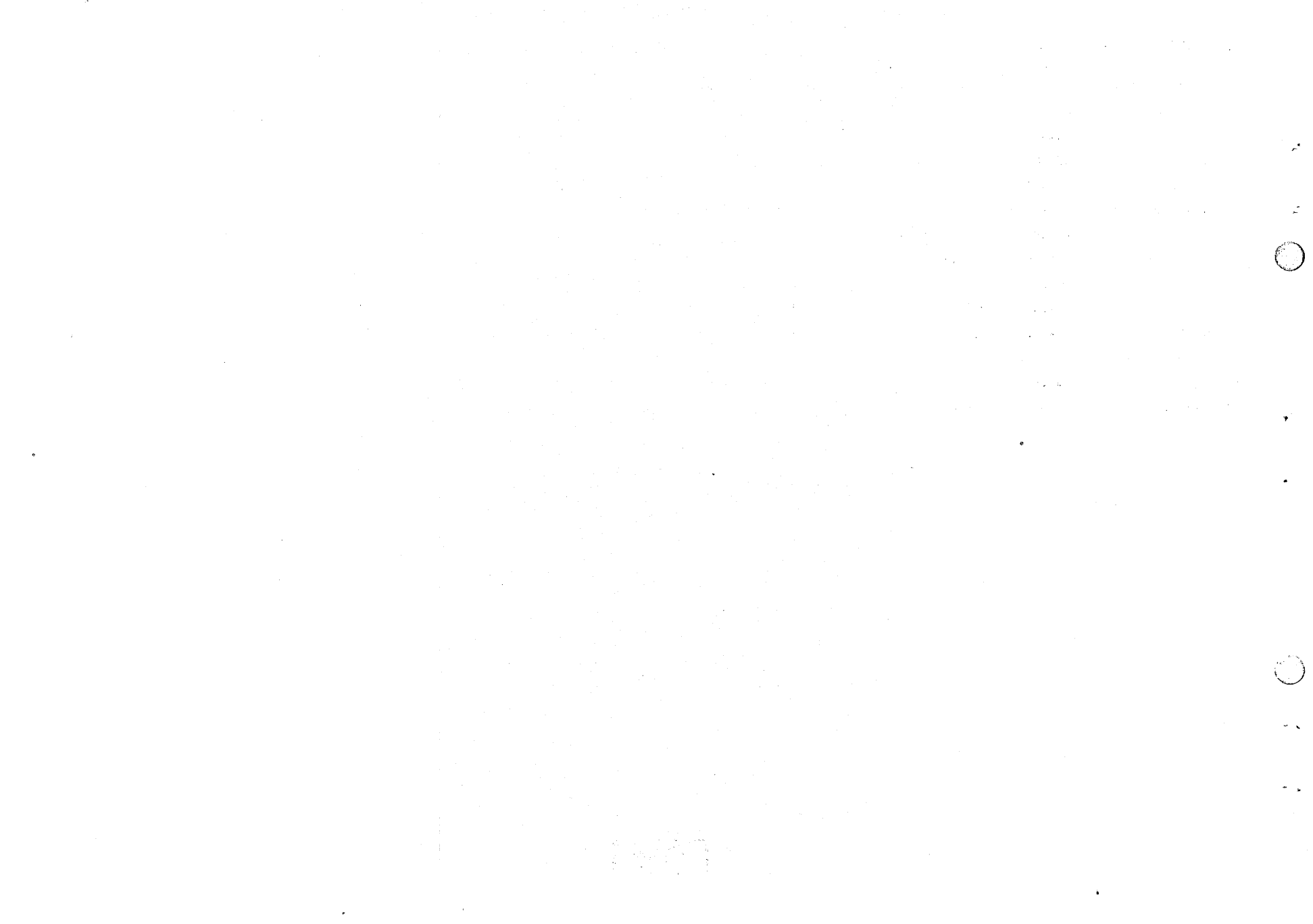

INDEX

NUMERICAL INDEX

PART NO.	REF. NO.	PART NO.	REF. NO.	PART NO.	REF. NO.	PART NO.	REF. NO.	PART NO.	REF. NO.	PART NO.	REF. NO.
5X3-W0001-00	29-32	5X3-11637-01	29-17	537-14181-16	5-21	3R3-16150-00	10- 5	5X4-21721-10-98	16- 5	5X3-22409-00	18-34
5X4-W1442-00	4-22	5X3-11638-01	2- 8	537-14184-00	5-22	537-16321-00	10- 8	5X3-21737-10	4-30	4L0-22472-00	18- 8
5X4-W2473-10	22- 1		29-22	280-14185-00	5-15	3R3-16325-00	10- 7		16- 6		18-31
5X3-11111-00	1- 1	4V2-11650-00	29-26	537-14186-00	5- 3	1W1-16351-00	10- 9	565-21746-00	15-12	3R4-22473-00	18- 7
5X3-11181-00	1- 2	4V2-11651-00	2- 4	2K5-14187-00	5- 5	1W1-16356-01	10-22	5X3-22110-00-35	17- 1		18-30
	29-33		29-27	168-14190-28	5- 4	2X3-16357-00	10-17	5X6-22123-00	17-33	3R4-22475-00	18- 6
5X3-11311-00	1- 5	3M5-11681-00	2- 5	214-14195-00	5- 2	1W1-16358-00	10-19	156-22127-00	17- 8		18-29
4V2-11351-00	1- 6		29-28	310-14196-00	5-26	1G8-16371-00	10- 6	322-22128-01	17- 7	5X3-22489-00	18- 5
	29-34	5X3-13565-00	4- 6	183-14197-01	5-23	3R3-16380-02	10-23		17-18		18-28
3R3-11400-00	2- 1	5X2-13581-00	4-12	2K5-14198-00	5-43	5X4-17121-01	11- 2	5X6-22129-00	18-57	5X3-22493-00	18- 9
3R3-11412-00	2- 2	1L8-13610-00	4- 1	363-14198-00	5-31	3R3-17131-01	11- 3	5X4-22141-00	17-10		18-32
4V2-11422-00	2- 3	1L8-13613-00	4- 2	4V3-1441K-00	4-13	3R3-17151-02	11- 4		17-20	5X3-22497-00	18-14
5X3-11611-00	2- 9	311-13616-01	4- 3	5X3-14411-00	4-17	3R3-17161-02	11- 5	5X3-22147-00	17- 2		18-37
	29- 3	10V-13621-00	4- 5	5X3-14412-10	4-18	5X4-17211-01	11- 9	1W1-22151-00	17- 9	5X3-23102-M0	20- 1
5X3-11611-10	2- 9		29-35	5X4-14462-00	4-19	3R3-17221-01	11-10		17-19	5X3-23103-M0	20-24
	29- 8	5X3-14101-00	5- 1	5X3-14453-00	4-20	3R3-17231-01	11-11	5X3-2217A-00	17-15	5X3-23110-L0	20- 7
5X3-11611-20	2- 9	537-14112-25	5-17	5X3-14455-00	4-28	3R3-17241-01	11-12	5X3-2217F-00	17-25		20-30
	29-13	537-14115-00	5- 7	1W1-14457-01	4-26	3R3-17251-02	11-13	5X6-2217H-00	17-35	5X3-23111-L0	20-15
5X3-11611-30	2- 9	1J4-14116-10	5-18	5X4-14458-00	4-23	3R3-17261-02	11-14	4V4-22178-00	14- 3		20-38
	29-18	278-14117-00	5- 6	5X4-14462-00	4-29	3R3-17411-00	11- 1	5X3-2218A-00	17-40	1W1-23114-L0	20-10
5X3-11611-40	2- 9	537-14122-00	5-12	2X4-14468-00	4-24	137-17417-00-05	9- 2	3Y1-22184-01	17- 4		20-33
	29-23	525-14123-00	5-36	5X3-14461-00	6- 1	3R3-17421-00	11- 8	4V4-22184-00	14- 4	4V5-23118-L1	20-23
5X3-11630-01	29- 1	537-14131-00	5-29	3R3-144613-00	6- 2	1G8-17461-10	11-29	5X4-22199-00	17-13		20-46
5X3-11630-11	29- 6	174-14134-00	5-38		29-36	1G8-17461-30	11-29	5X3-22210-00-6W	18-24	122-23119-01	20-21
5X3-11630-21	29-11	500-14135-00	5-39	5X4-14753-00	6- 7	1W1-17461-20	11-29	5X3-22210-10-6W	18- 1		20-44
5X3-11630-31	29-16	537-14136-00	5-20	565-14771-00	6- 4	3R3-17471-00	11-25	5X3-22212-00-6W	18-19	5X3-23126-L0	20- 2
5X3-11630-41	29-21	164-14137-00	5-19	5X3-15111-00	7- 1	5X4-18101-00	13- 1		18-42	122-23129-00	20-19
5X3-11631-01-97	2- 8	363-14137-00	5-32	4V2-15121-00	7- 2	5X4-18110-01	13- 2	3R4-22213-00	18-17		20-42
	29- 2	278-14141-52	5-10	3R3-15128-01	7-12	1W6-18113-00	13- 3		18-40	5X3-23136-L0	20-25
5X3-11631-01-98	2- 8	193-14142-50	5-11	1G8-15362-00	8- 5	3R3-18140-00	12- 7	3R4-22214-00	18-20	5X3-23141-L0	20-11
		137-14143-36	5- 8	2N4-15371-00	7- 7	1W1-18177-00	12- 9		18-43		20-34
1J4-11633-00	2-10	137-14143-38	5- 8	2K7-15383-00	11-27	3R4-18185-00	12- 2	5X6-22216-00	18- 3	1W1-23142-L0	20-12
	29- 4	137-14143-40	5- 8	3R3-15411-00	8- 1	3R3-18511-00	12-10		18-26		20-35
	29- 9	537-14146-00	5-16	3R3-15421-00	8- 9	3R3-18512-00	12-11	3R4-22221-01	18-16	3R8-23144-L0	20- 5
	29-14	214-14147-00	5-14	3R3-15431-00	8-12	3R3-18513-00	12-12		18-39		20-28
	29-19	354-14147-00	5-37	3R3-15451-01	8- 2	3R4-18531-00	12-14	3R4-22223-00	18-22	1W1-23145-L0	20- 4
	29-24	537-14153-00	5- 9		29-40	3R4-18535-00	12-15		18-45		20-27
4V2-11634-00	2-11	2K5-14155-00	5-30	4V2-15455-00	8-10	5X4-18540-00	12- 1	5X3-22224-00	18-21	3J2-23147-00	20-17
	29- 5	2K5-14158-00	5-27		29-39	3R4-18561-00	12- 5		18-44		20-40
	29-10	127-14161-00	5-44	3R3-15618-01	9-18	5X3-21110-00-33	14- 1	5X6-22226-00	18-12	3R8-23148-L0	20- 6
	29-15	537-14161-00	5-13	5X3-15620-00	9-13	288-21376-00	27- 8		18-35		20-29
	29-20	537-14162-00	5-34	5X3-15621-00	9-14	3R3-2148A-00	14- 5	3R4-22228-00	18-10	4A1-23156-00	20- 3
	29-25	1M1-14169-00	5-28	3R3-15641-00	9- 5	5X6-21511-10	15- 1		18-33		20-26
5X3-11635-01	2- 8	174-14171-00	5-41	3R3-15651-01	9- 1	3R3-21611-11	15- 6	5X4-22261-00	18-60	509-23158-L0	20-18
	29- 7	802-14173-00	5-42	248-15654-00	9- 7	5X3-21620-00	15-11	3R3-22262-00	18-61		20-41
5X3-11636-01	2- 8	802-14174-00	5-40	3R3-15660-00	9- 4	5X3-21642-00	15-13	5X3-22401-00	18-25	3R6-23170-L0	20- 8
	29-12	537-14175-00	5-33	3R3-15666-00	9- 9	5X3-21652-00	17-23	5X3-22401-10	18- 2		20-31
5X3-11637-01	2- 8	537-14178-00	5-35	3R3-16111-00	10- 1	5X4-21711-10-98	16- 1	5X3-22409-00	18-11	3R6-23173-L0	20- 9

NUMERICAL INDEX

PART NO.	REF. NO.	PART NO.	REF. NO.	PART NO.	REF. NO.
92901-04100	3-10	93306-20205	24- 4	94330-21088	23-16
92901-04600	3-11	93306-20529	2-14	94416-21265	23-17
92901-05100	3- 6	93306-30102	23- 2	94416-21346	23-17
92901-05600	3- 7	93306-30103	23- 6	94418-18312	24-15
92901-06100	3-13	93306-30203	24- 5	94418-18347	24-15
	4-33	93306-30303	11-20	94585-20106	24-34
	6- 6	93306-30406	2-13	94685-20001	24-35
	15-17	93306-30411	11-23	*	1-10
	16- 4	93310-216J2	2-12	95301-06600	10-21
	16-10		29-31		23-12
	21- 5	93310-422H0	2- 7		24-13
	21-28		29-30	95301-06700	26-24
	22- 9	93311-31515	11-22	95301-08700	24-27
	25-24	93311-41530	11-21	95302-10700	18-48
92901-06200	8-16	93315-21429	10-27	95601-06100	15-10
	10-20	93317-22023	17-26		28- 6
	26-18	93317-22208	17-17		28-14
92901-06600	3-14	93332-00008	19- 9	95601-08100	26- 4
	4- 8	93332-00023	19- 8		26- 9
	21- 6	93410-17037	9-11	95601-10100	18-55
92901-08200	14-14	93410-20038	11- 7	95602-06100	22-12
	16-11	93410-22039	11-18	95602-08100	14-10
	24-24	93410-30012	9- 8	95701-08100	19- 4
92902-04100	5-25	93430-09038	26-14	95802-08040	17-14
92902-06100	15- 4	93430-10016	13- 9	95811-08100	14-11
	15- 9	93440-15012	9- 3	95811-08165	14-12
	18-63		11-16	95811-10020	26-11
	22-13	93440-50078	18-23	95821-08035	19- 7
92902-06600	18-64		18-46	95821-08040	19- 2
	22-11	93503-16010	10-18	95821-08055	19- 3
92902-12200	26-13	93507-32009	9-16	97301-06012	6- 5
92906-05100	28- 8	93604-16092	10-28		21- 4
	28-16	93604-26132	18-15		22- 8
	13- 5		18-38	97301-06016	15- 8
93101-12060	9-12	93608-25150	13- 6	97301-06020	26-23
93101-17062	23- 5	93700-06004	17-39	97301-06025	4- 7
93102-18008	2-16		18-53	97302-06020	15- 3
93102-25258	11-24	94111-18781	24-17	97302-06035	22-10
93102-26042	2-15	94130-21731	23-14	97302-08050	14- 9
93103-28126	10-26	94130-21732	23-14	97321-06012	11-26
93104-14004	24- 6	94141-18733	24-17	97321-06020	13- 4
93106-22017	17-27	94227-21123	23-15	97602-03108	4- 4
93109-20029	17- 5	94230-21126	23-15	98501-04005	18- 4
93109-22019	8- 6	94235-18085	24-18		18-27
93210-14104	29-38	94241-18153	24-18	98501-04008	3- 9
	10- 4	94325-18043	24-19	98501-04016	5-24
93210-20027	12- 3	94330-18087	24-19	98501-05030	3- 5
93306-00422	12-16	94330-21084	23-16	98506-05016	25-10

NUMERICAL INDEX

PART NO.	REF. NO.	PART NO.	REF. NO.
98506-05020	28- 7		
	28-15		
98606-04012	25- 9		
98701-05016	12- 6		
98902-06018	21- 7		

PARTS NAME INDEX

DESCRIPTION	REF. NO.
AIR VALVE COMP.	20-16
*	20-39
ARM, float	5- 5
ARM, relay	17-15
AXLE, drive	11- 8
AXLE, main (13T)	11- 1
AXLE, wheel	23-22
*	24-30
BALL	9-16
*	10-18
BAND	4-28
BAND, battery	4-16
BAND, boot	20-14
*	20-37
BAND, rim (2.50-18)	24-19
BAND, rim (3.00-18)	24-19
BAND, rim (3.00-21)	23-16
*	23-16
BAND, switch cord	3-16
*	3-17
*	15-14
*	28-18
BAND, tank filling 1	21- 8
BAND, tool	27- 8
BAR, shift fork guide 1	12-14
BAR, shift fork guide 2	12-15
BEARING	12- 3
*	19- 8
*	19- 9
BEARING (B6201)	12-16
BEARING (B6202)	24- 4
BEARING (B6205C4)	2-14
BEARING (B6301)	23- 2
BEARING (B6301Z)	23- 6
BEARING (B6302Z)	24- 5
BEARING (B6303Z)	11-20
BEARING (B6304)	11-23
BEARING (B6304C3)	2-13
BEARING, cylindrical	2- 7
*	2-12
*	10-27
*	11-21
*	11-22
*	17-17
*	17-26
*	29-30
*	29-31
*	21-15
BODY, caP	21-15

PARTS NAME INDEX

DESCRIPTION	REF. NO.
BODY, float chamber 1	5-21
BOLT	4- 7
*	6- 5
*	6- 8
*	7- 5
*	7- 6
*	11-26
*	13- 4
*	14- 9
*	15- 3
*	15- 8
*	17-29
*	18-47
*	18-52
*	21- 4
*	22- 4
*	22- 8
*	22-10
*	23-11
*	24-12
*	24-26
*	25-20
*	26- 3
*	26- 8
*	26-23
*	28- 5
*	28-13
BOLT, caP	20-15
*	20-38
BOLT, flange	14-11
*	14-12
*	17-14
*	19- 2
*	19- 3
*	19- 7
*	26-11
BOLT, hexagon socket head	20-20
*	20-43
*	20-48
*	24-22
*	5-34
BOLT, starter lever	5-34
BOLT, stopper	12- 9
BOLT, stud	1- 3
*	1- 7
BOLT, washer based	19- 5
*	26-10
BOLT, with washer	21-17
BOOT	20-13

PARTS NAME INDEX

DESCRIPTION	REF. NO.
BOOT	20-36
BOSS, clutch	10- 6
BOSS, kick crank	9-14
BRACKET, footrest 2	26- 6
BRACKET, seat	21-26
*	22- 3
*	22- 7
BRAKE SHOE COMP.	23- 8
*	24- 8
BREATHER	7- 7
BUMP, stop	18- 9
*	18-32
BUSH	14- 4
*	17- 4
BUSH 1	17-33
BUSH, bimetal formed	17-34
*	18-13
*	18-36
BUSH, rear shock absorber	18- 3
*	18-26
BUSH, shock absorber lower	18-12
*	18-35
BUSH, solid	17- 6
*	17-28
*	18-51
*	18-58
C.D.I. MAGNETO ASSY	3- 1
C.D.I. UNIT ASSY	27- 6
CABLE, brake	25-12
CABLE, clutch	25-18
CABLE, throttle 1	25-11
CAMSHAFT	23-13
*	24-10
CAP	5-28
CAP, case	18- 8
*	18-31
CAP, cleaner case 1	4-18
CAP, grip lower	25- 7
CAP, grip upper	25- 6
CAP, plunger	5-40
CAP, wire	25- 8
CARBURETOR ASSY 1	5- 1
CASE, air cleaner 1	4-17
CHAIN (D1D520DS-106L)	24-34
CHAMBER, air	4-12
CIRCLIP	9- 3
*	9- 8
*	9-11

PARTS NAME INDEX

DESCRIPTION	REF. NO.
CIRCLIP	11- 7
*	11-16
*	11-18
*	13- 9
*	18-23
*	18-46
*	26-14
CLAMP	3- 8
*	4- 9
*	25-22
*	27- 3
CLAMP, hose	4-10
*	4-11
*	4-21
CLIP	4-15
*	4-27
*	5-19
*	5-32
*	9- 6
*	21-21
CLIP, oil seal	20- 3
*	20-26
CLIP, Piston Pin	2-11
*	29- 5
*	29-10
*	29-15
*	29-20
*	29-25
COIL, charge	3- 4
COLLAR	6-11
*	7- 3
*	11-30
*	17-16
*	19-13
*	21-19
*	23-20
*	24-28
CONNECTING ROD ASSY	29-26
COVER	18-16
*	18-39
COVER, ball race 2	19-10
COVER, crankcase 1	8- 1
COVER, crankcase 2	8- 9
COVER, crankcase 3	8-12
COVER, dust	17-35
COVER, dust seal	20- 6
*	20-29
COVER, handle lever 1	25-13

PARTS NAME INDEX

DESCRIPTION	REF. NO.
COVER, handle lever 1	25-19
COVER, hub dust	23-21
*	24-29
COVER, kick lever	9-18
COVER, Plunger cap	5-42
COVER, semi-double seat	22- 2
COVER, shift Pedal	13- 3
COVER, side 1	16- 1
COVER, side 2	16- 5
COVER, thrust 1	17- 7
*	17-18
COVER, thrust 2	18-57
CRANK 1	2- 2
CRANK 2	2- 3
CRANKCASE 1	7- 1
CRANKCASE 2	7- 2
CRANKSHAFT ASSY	2- 1
CROWN, handle	19- 1
CYLINDER COMP., front fork	20- 8
*	20-31
CYLINDER 1	1- 5
DAMPER	27- 7
DAMPER, locating 1	16- 7
*	21-23
DAMPER, locating 2	21- 2
DAMPER, locating 3	21-24
DAMPER, seat	22- 5
DAMPER, sub tank	18-60
DRIVEN GEAR ASSY (62T)	10- 5
DUMPER SUB ASSY	18- 2
*	18-25
ELEMENT, air cleaner	4-22
EMBLEM	4-13
*	4-30
*	16- 6
*	19-16
EMBLEM, rear arm	17-40
EXHAUST PIPE ASSY 1	6- 1
FENDER, front	15- 1
FENDER, rear	15- 6
FLANGE, spacer	23- 4
*	24- 3
FLOAT	5-15
FOOTREST 1	26- 1
FOOTREST 2	26- 5
FORK, shift 1	12-10
FORK, shift 2	12-11
FORK, shift 3	12-12

PARTS NAME INDEX

DESCRIPTION	REF. NO.
FRAME COMP	14- 1
FRONT FORK ASSY (L.H)	20- 1
FRONT FORK ASSY (R.H)	20-24
FUEL COCK ASSY 1	21- 9
FUEL TANK COMP.	21- 1
GASKET	5-31
*	5-43
*	7-11
*	8- 8
*	20-10
*	20-18
*	20-33
*	20-41
*	21-10
*	29-37
GASKET KIT	29-32
GASKET 1	8-10
*	29-39
GASKET, cap	21-16
GASKET, crankcase cover	8- 2
*	29-40
GASKET, cylinder	1- 6
*	29-34
GASKET, cylinder head 1	1- 2
*	29-33
GASKET, drain Plug	20-19
*	20-42
GASKET, exhaust Pipe	6- 2
*	29-36
GASKET, float chamber	5-22
GASKET, valve seat	4- 5
*	29-35
GEAR, kick (25T)	9- 5
GEAR, Primary drive (18T)	10- 1
GEAR, sprocket idle (25T)	9- 1
GEAR, 1st wheel (32T)	11- 9
GEAR, 2nd Pinion (14T)	11- 2
GEAR, 2nd wheel (26T)	11-10
GEAR, 3rd wheel (24T)	11-11
GEAR, 3rd/4th Pinion (16T,20T)	11- 3
GEAR, 4th wheel (25T)	11-12
GEAR, 5th Pinion (19T)	11- 4
GEAR, 5th wheel (21T)	11-13
GEAR, 6th Pinion	11- 5
GEAR, 6th wheel	11-14
GRAPIC SET	21-25
GRIP (L.H)	25- 2
GRIP (R.H)	25- 3

PARTS NAME INDEX

DESCRIPTION	REF. NO.
GROMMET	6-10
*	18-59
GUARD, flap	15-13
GUIDE	4-23
GUIDE, cable	20-49
GUIDE, spring 1	18-20
*	18-43
GUIDE, spring 2	18-21
*	18-44
HANDLEBAR	25-1
HEAD, cylinder 1	1-1
HOLDER	7-12
HOLDER, damper	21-3
HOLDER, guide	5-30
HOLDER, handle upper	19-6
HOLDER, kick gear	9-7
HOLDER, lever lower 1	28-2
*	28-10
HOLDER, lever 1	28-1
HOLDER, lever 2	28-9
HOLDER, sub tank	18-61
HOSE	4-14
*	7-8
*	21-20
*	21-22
HOUSING, seal ring	18-7
*	18-30
HUB, front	23-1
HUB, rear	24-1
IGNITION COIL ASSY	27-1
INNER TUBE COMP.1	20-7
*	20-30
JET, main (#180)	5-8
JET, main (#190)	5-8
JET, main (#200)	5-8
JET, Pilot (#50.0)	5-11
JOINT, air cleaner 1	4-20
JOINT, cable	25-16
JOINT, carburetor	4-6
JOINT, chain	24-35
KEY, straight	2-17
*	12-4
KEY, woodruff	2-18
KICK AXLE ASSY	9-4
KICK CRANK ASSY	9-13
LEVER 1	28-3
LEVER 2	28-11
LEVER, camshaft	24-11

PARTS NAME INDEX

DESCRIPTION	REF. NO.
LEVER, camshaft 1	23-10
LEVER, starter 1	5-33
MUD GUARD COMP.	15-11
NEEDLE	5-18
NEEDLE VALVE ASSY	5-4
NIPPLE, grease	17-39
*	18-53
NOZZLE, main	5-10
NUT	1-4
*	1-8
*	3-15
*	9-20
*	10-3
*	10-16
*	10-21
*	11-32
*	17-12
*	17-22
*	18-18
*	18-41
*	18-48
*	19-11
*	23-12
*	24-13
*	24-27
*	25-21
*	26-24
NUT, adjusting	18-14
*	18-37
NUT, cable adjusting	5-44
NUT, castle	23-23
*	24-31
NUT, flange	19-4
NUT, self-locking	14-13
*	17-31
*	24-23
NUT, throttle screw	5-13
NUT, u	14-10
*	15-10
*	18-55
*	22-12
*	26-4
*	26-9
*	28-6
*	28-14
NUT, wing	4-25
*	26-22
O-RING	5-14

PARTS NAME INDEX

DESCRIPTION	REF. NO.
O-RING	5-37
*	8-6
*	10-4
*	20-17
*	20-40
*	21-11
*	29-38
OIL SEAL	2-15
*	2-16
*	9-12
*	10-26
*	11-24
*	13-5
*	17-5
*	17-27
*	20-4
*	20-27
*	23-5
*	24-6
PAD, seat	22-6
PEDAL, brake	26-12
PIN	17-36
*	26-21
PIN, clevis	9-17
*	25-14
*	26-17
PIN, cotter	9-19
*	17-32
*	17-38
*	18-50
*	18-56
*	23-24
*	24-33
*	25-17
*	26-19
PIN, crank 1	2-5
*	29-28
PIN, dowel	1-9
*	7-4
*	8-4
*	10-28
*	13-6
*	18-15
*	18-38
PIN, float	5-3
PIN, piston	2-10
*	29-4
*	29-9

PARTS NAME INDEX

DESCRIPTION	REF. NO.
PIN, Piston	29-14
*	29-19
*	29-24
PIN, straight	12-13
PIPE	5-23
*	5-26
PISTON (STD)	2- 8
*	2- 8
*	29- 2
*	29- 2
PISTON (1ST O/S 0.25MM)	2- 8
*	29- 7
PISTON (2ND O/S 0.50MM)	2- 8
*	29-12
PISTON (3RD O/S 0.75MM)	2- 8
*	29-17
PISTON (4TH O/S 1.00MM)	2- 8
*	29-22
PISTON ASSY (STD)	29- 1
PISTON ASSY (1ST O/S)	29- 6
PISTON ASSY (2ND O/S)	29-11
PISTON ASSY (3RD O/S)	29-16
PISTON ASSY (4TH O/S)	29-21
PLATE	5-16
PLATE, bearing cover	11-27
PLATE, brake shoe	23- 7
*	24- 7
PLATE, clutch 2	10- 7
PLATE, cover	11-25
PLATE, element fitting	4-24
PLATE, friction	10- 8
PLATE, number	19-12
PLATE, Pressure 1	10- 9
PLATE, Push	10-19
PLATE, side 1	12- 5
PLATE, starter lever	5-35
PLUG	7- 9
*	14- 2
*	14-16
PLUG CAP ASSY	27- 4
PLUG, drain	20-21
*	20-44
PLUG, oil level	8- 5
PLUG, screw	5- 7
PLUG, sPark (CHAMPION N-84)	1-10
PLUG, straight screw	7-10
PLUNGER, starter	5-41
PROTECTOR	17-23

PARTS NAME INDEX

DESCRIPTION	REF. NO.
PROTECTOR, chain	17- 2
PULLER, chain 1	24-25
PULLER, rotor	14-18
PUSH LEVER ASSY	10-23
REAR ARM COMP.	17- 1
REED VALVE ASSY	4- 1
REED, valve	4- 2
RIM (1.60-21)	23-17
*	23-17
RIM (1.85-18)	24-15
*	24-15
RING, leaf	25- 5
RING, Piston	2- 9
*	2- 9
*	2- 9
*	2- 9
*	2- 9
*	29- 3
*	29- 8
*	29-13
*	29-18
*	29-23
ROD, brake	26-16
ROD, connecting	2- 4
*	29-27
ROD, connecting 1	17-25
ROD, Push	18- 5
*	18-28
ROD, Push 1	10-22
ROD, Push 2	10-17
ROTOR ASSY	3- 2
SCREW	21-14
SCREW, air adjusting	5-36
SCREW, bind	21- 7
SCREW, boot band	20-22
*	20-45
SCREW, flat head	11-28
*	12- 6
SCREW, lever fitting	21-12
SCREW, oval head	25- 9
SCREW, Pan head	3- 5
*	3- 9
*	3-12
*	4-32
*	5-24
*	7-13
*	8- 3
*	8- 7

PARTS NAME INDEX

DESCRIPTION	REF. NO.
SCREW, Pan head	8-11
*	8-13
*	8-15
*	15-16
*	16- 3
*	16- 9
*	18- 4
*	18-27
*	18-62
*	19-15
*	21-27
*	25-10
*	25-23
*	27- 2
*	28- 7
*	28-15
SCREW, Pan head with washer	4- 4
SCREW, throttle	5-12
SCREW, with washer	4-34
*	10-11
*	17- 3
*	17-24
SEAL	4-19
*	4-26
*	4-29
SEAL, camshaft	24-14
SEAL, dust	18- 6
*	18-29
*	20- 5
*	20-28
SEAL, Guard	17- 9
*	17-19
SEAL, mud Guard	15-12
SEAT, sPring	5-20
SEAT, sPring lower	18-22
*	18-45
SEAT, sPring upper	18-17
*	18-40
*	20-12
*	20-35
SEGMENT	12- 2
SEMI-DOUBLE SEAT ASSY	22- 1
SHAFT	14- 5
SHAFT, Pivot	17-10
*	17-20
SHIFT CAM ASSY	12- 1
SHIFT PEDAL ASSY	13- 2
SHIFT SHAFT ASSY	13- 1

PARTS NAME INDEX

DESCRIPTION	REF. NO.
SHIM (0.3T)	17- 8
SHIM (0.5T)	9- 2
SHOCK ABSORBER ASSY, rear	18- 1
*	18-24
SILENCER, exhaust	6- 7
SPACER	9- 9
*	10-13
*	13- 7
*	20-23
*	20-46
*	23- 3
SPACER, bead	23-19
*	24-20
SPACER, bearing	24- 2
SPANNER, special	14-19
SPINDLE, taper	20- 9
*	20-32
SPOKE SET, front	23-18
SPOKE SET, rear	24-16
SPRING	18-19
*	18-42
SPRING, air adjusting	5-38
SPRING, compression	9-15
*	10-10
*	26-20
SPRING, front fork	20-11
*	20-34
SPRING, plunger	5-39
SPRING, tension	6- 3
*	23- 9
*	24- 9
SPRING, throttle valve	5-29
SPRING, torsion	9-10
*	10-24
*	12- 8
*	13- 8
*	26- 2
*	26- 7
*	26-15
SPROCKET, drive (11T)	11-29
SPROCKET, drive (12T)	11-29
SPROCKET, drive (13T)	11-29
SPROCKET, driven (46T)	24-21
SPROCKET, driven (48T)	24-21
SPROCKET, driven (50T)	24-21
SPROCKET, driven (52T)	24-21
STAND, side	26-25
STATOR ASSY	3- 3

PARTS NAME INDEX

DESCRIPTION	REF. NO.
STAY, muffler 1	6- 4
STOPPER LEVER ASSY	12- 7
STOPPER, reed valve	4- 3
SUPPORT, bump stop	18-10
*	18-33
SUPPORT, chain	17-13
SWITCH, handle 1	28-17
TENSIONER	14- 3
TIRE (110/90-18 61M)	24-17
TIRE (3.00-21)	23-14
*	23-14
TIRE (4.10-18)	24-17
TOOL KIT	14-17
TOP, mixing chamber	5-27
TUBE (2.75-21)	23-15
TUBE (3.00-21)	23-15
TUBE (3.50-18)	24-18
TUBE (4.10-18)	24-18
TUBE, outer 1	20- 2
TUBE, outer 2	20-25
TUBE, throttle guide	25- 4
UNDER BRACKET COMP.	20-47
UPPER BRACKET SUB ASSY	18-11
*	18-34
VALVE, throttle 1	5-17
WASHER	2- 6
*	11-19
*	15- 5
*	18-64
*	22-11
*	26-13
*	29-29
WASHER, claw	14-15
WASHER, lock	10-15
*	11-31
WASHER, main jet	5- 9
WASHER, needle valve	5- 2
WASHER, plain	8-16
*	10-20
*	14-14
*	16-11
*	24-24
*	26-18
WASHER, Plate	3- 7
*	3-11
*	3-14
*	4- 8
*	4-31

PARTS NAME INDEX

DESCRIPTION	REF. NO.
WASHER, Plate	6- 9
*	8-14
*	10-12
*	10-14
*	10-25
*	11- 6
*	11-17
*	14- 6
*	14- 7
*	14- 8
*	15- 2
*	15- 7
*	15-15
*	16- 2
*	16- 8
*	17-11
*	17-21
*	17-30
*	17-37
*	18-49
*	18-54
*	19-14
*	21- 6
*	21-13
*	21-18
*	23-25
*	24-32
*	25-15
*	28- 4
*	28-12
WASHER, Plate (1.0T)	11-15
WASHER, Plug screw	5- 6
WASHER, spring	3- 6
*	3-10
*	3-13
*	4-33
*	5-25
*	6- 6
*	10- 2
*	15- 4
*	15- 9
*	15-17
*	16- 4
*	16-10
*	18-63
*	21- 5
*	21-28
*	22- 9

PARTS NAME INDEX

DESCRIPTION	REF. NO.
WASHER, spring	22-13
*	25-24
*	28- 8
*	28-16
WIRE HARNESS ASSY	27- 5

COPY RIGHT: ALL RIGHTS RESERVED
NO PART OF THIS PUBLICATION MAY BE
REPRODUCED WITHOUT PERMISSION.



YAMAHA

YAMAHA MOTOR CO., LTD.
2500 SHINGAI IWATA-SHI SHIZUOKA-KEN JAPAN

PRINTED IN JAPAN

First edition Jul., 1982

TG